



## Study of Auto changeover system for Backup Generator using PLC

Shivani Kurhe\*, Yogita Khairnar\*, Ganesh Takate\*, Prof. Vikram Patil\*\* and Prof. Harshvardhan\*\*

\*Undergraduate Students, Electrical Department, Sandip Inst. of Engineering & Management, Nashik

\*\*Assistant Professor, Electrical Department, Sandip Inst. of Engineering & Management, Nashik

(Corresponding author: Shivani Kurhe)

(Received 07 February, 2017 Accepted 23 April, 2017)

(Published by Research Trend, Website: [www.researchtrend.net](http://www.researchtrend.net))

**ABSTRACT:** Power failure or outage is the main issue regarding to continuity of supply as industries, factories with constant power failure are not efficient. The introduction of auto-changeover system is mainly done to reduce the problems in manual switching along with challenges in smooth switching. This paper presents the design and construction of auto-changeover system using Programmable Logic Controller(PLC), as the switching operation done by PLC it automatically restores the power supply by using generator backup when mains supply. This helps in reducing the time consumption required for switching operation.

**Keywords:** Automatic Changeover, Switching, Circuit Breaker (C.B) Generator, Power Supply, PLC

### I. INTRODUCTION

Power failure or outage is the main issue regarding to continuity of supply as industries, factories with constant power failure are not efficient. The introduction of auto-changeover system is mainly done to reduce the problems in manual switching along with challenges in smooth switching. This paper presents the design and construction of auto-changeover system using PLC, as the switching operation done by PLC it automatically restores the power supply by using generator backup when mains supply. This helps in reducing the time consumption required for switching operation.

In this world of increasing automation PLC struck our mind. For controlling, monitoring, integrating system with newer technology PLC is very efficient tool to automate. As PLC has rugged type construction hence it has ability to withstand in any situation like vibrations, temperature, humidity and noise. In industry the most sensible and important loads are controlled through the PLC. The PLC automation has one of the advantage that its easy programming language and which can be easily understood by workers. For handling and controlling PLC there is no need of expertise, as ordinary worker can also operate it easily.

Another advantage of PLC is its fast response, which helps in maintain stability of the system. The auto changeover system is used where frequent power fails also it used where continuous supply needed such as hospitals, educational institutions etc.

*A. Manual source-changeover system:* This is the easiest type changeover system which mainly controlled manually. For this manpower is required and consequently the time required for operation is more. A manual source-changeover system is formed of 2 or 3

automatically interlocked manually-operated circuit breakers or switch-disconnections.

*B. Remote-operated source-changeover system:* This is the foremost ordinarily utilized system for devices with high ratings (above four hundred A). No human intervention is needed. Transfer from the traditional to the replacement supply is controlled electrically. A remote-controlled source-changeover system is formed of 2 or more circuit breakers or switch-disconnections connected by an electrical interlocking system that will have totally different configurations.

*C. Automatic source-changeover systems:* An automatic source changeover is an advance version of remotely operated system consists of various controllers with programmable operative modes. It ensures the emergency supply replacement also helps in managing the power sources. The automatic controller could also be fitted with a choice for communication with a supervisor.

### II. CHANGEOVER DESIGN SETTING

In designing and construction of this change-over switch, a generator with the capacity in few kVA was used and its rating determines the ratings of the components and circuit elements to be used. It does not function with a faulty generating set and the generator must have a manual starter and engine stopper which is a sine function of the automatic change-over. This automatic change-over switch is designed and constructed with the aim of achieving the following automatic actions.

1. To automatically switch on the generator and switch over the load to the generator whenever there is mains power failure.

2. To automatically switch over to mains supply once restored and simultaneously switch off the generator. However, a good switch should be the one whose contact is made in such as to limit the arc formation by having no contact-bounce and by having contacts made of good conductive, corrosion resistance and wears resistance materials. Change-over switch must have adequate insulation and must be so constructed and located as not to constitute a potential hazard. A good change-over switch should also have tight contact points so as to limit or eliminate the possibility of partial contact at the contact point. The partial contact may lead to fire outbreak or possible damage to the contactor itself.

The following are the advantages that are associated to the change-over switch.

1. It minimizes damages to lives and equipment since it has its own monitoring system and its switching requires no human contact with the switch, thus eliminating human error.
2. It reduces change-over time to a minimum, due to its fast response to power restoration
3. It maintains high quality of service through its fast and prompt response.

The stand-by generator set is commonly used to supply emergency power to most of the power consumers where the mains supply is unstable. The automatic change-over switch can be used in any place where alternative power is needed to complement the main power supply. In this project, a generating set is used as an alternative power supply. Thus, it is very important to note the necessary peripherals to be used with the automatic changeover switch;

- (a) The generator must have electrical 'starting and stopping' facility
- (b) The generator's battery has to be in good condition always
- (c) The inter-connecting cables must be in good order

This rectification is also called full wave rectifier circuit. And also filtering is required for pure dc output. The filtering is made by connecting capacitor between phase and neutral terminal. The rectification and filtering is made in all three phases and all are identical connection Automatic changeover switch with generator starting / shut-down facility has been designed to help operator reduce the stress and loss of time associated with the starting and shutting down of the alternative sources of supply (generator).

One of the main functions of the control panel is the detection of a drop in voltage or a complete failure of the normal source of power. In general, all phases are monitored. Failure points are defined as a drop in voltage below a pre-set setting on any phase. Voltage and frequency information is provided by the

sensors in the control panel to determine load availability. The minimal voltage and frequency must be attained before transfer of the load to the new or used generator. This is to ensure the generator set has the ability to accept the load.

### III. SYSTEM CONFIGURATION

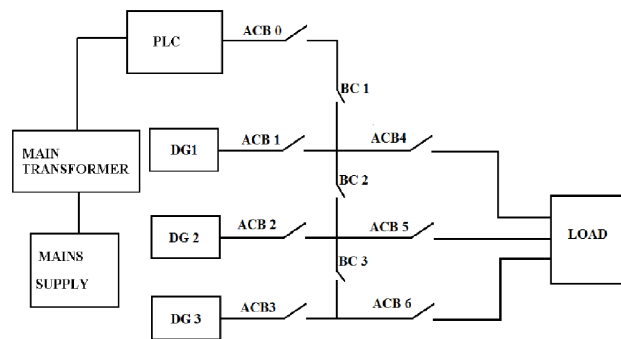

Fig. 1. Block diagram of prototype model.

At normal condition the load is served from mains supply through the main transformer and C.B, the PLC controls all the system and gives command according to condition occurs. Whenever disturbances like occurrence of fault or outages take place, the PLC sends command signal to turn on the generator backup. As per requirement of load the generator backup is fed to the load. If there some problem take place in case of generator supply, that single DG set remain off and remaining two DG set will supply the load through bus coupler, as bus coupler arrangement is provided. When mains get off, there some time delay of 25 sec is provided for starting the generator. This done because there may some transients occurs on the system which may be temporary in nature, hence such time delay is given.

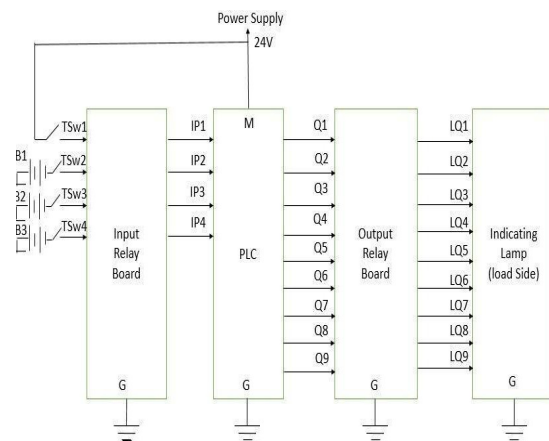

Fig. 2. Circuit diagram of auto changeover system.

The total switching operation is shown in table which gives the exact working condition of C.B and bus coupler.

Programmable Logic Controller (PLC) is a digital computer used for the automation of various electro-mechanical processes in industries.

**IV. INTERFACING PLC SYSTEM**

**Table 1: Switching Logic of Generator.**

LO AD	ACB&BC CONDITION		GENERATOR SET CONDITION			MAIN
	BC	ACB	DG3	DG2	DG 1	
ON	BC1 BC2 BC3	ACB0, ACB4, ACB5, ACB6	OFF	OFF	OFF	ON
ON	OFF	ACB1-ACB4, ACB2-ACB5, ACB3-ACB6	ON	ON	ON	OFF
ON	BC2	ACB2,ACB5, ACB3,ACB6	ON	ON	OFF	OFF
ON	BC2	ACB1, ACB4, ACB3, ACB6	ON	OFF	ON	OFF
ON	BC3	ACB1, ACB4, ACB2, ACB5	OFF	ON	ON	OFF
ON	BC2 BC3	ACB3,ACB4 ACB5,ACB6	ON	OFF	OFF	OFF
OF F	OFF	OFF	OFF	OFF	OFF	OFF

These controllers are specially designed to survive in harsh situations and shielded from heat, cold, dust, and moisture etc. PLC consists of a microprocessor which is programmed using the computer language. The program is written on a computer and is downloaded to the PLC via cable.

These loaded programs are stored in nonvolatile memory of the PLC. During the transition of relay control panels to PLC, the hard wired relay logic was exchanged for the program fed by the user. A visual programming language known as the Ladder Logic was created to program the PLC.

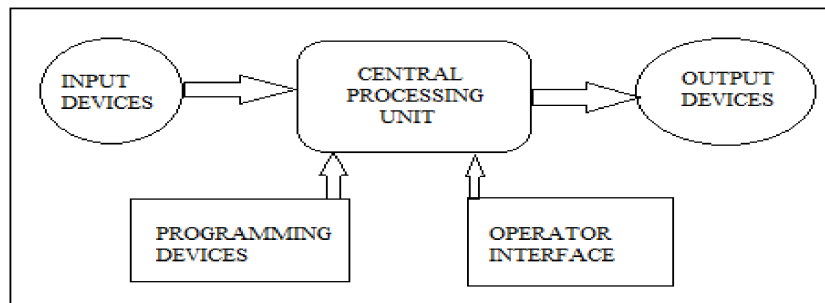

**Fig. 3.** Block diagram of PLC.

There are various programming languages are used for PLC programming, such as;

1. Ladder Diagram
2. Functional Block Diagram
3. Sequential Function Chart
4. Instruction List
5. Structured Text.

**V. ADVANTAGES**

1. It insures a constant power supply without any interruption.
2. Ideal for automatic switching as changeover happens automatically and mainly controlled by software hence no need to design complex hardware.
3. It reduces the stresses on manpower and operation is easy to handle.
4. Improve system stability and reliability.

**Table 2: PLC Specifications.**

72 X 90 X 55 MM / 2.83 X 3.54 X 2.16 IN	DIMENSION	GENERAL TECHNICAL
APPROX. 190 Gm	WEIGHT	
INPUTS/OUTPUTS, BUILT-IN : 8 INPUTS / 8 OUTPUTS	DATA RETENTION	
24 V – 47 TO 63 HZ	INPUT POWER	POWER SUPPLY
20.4 TO 26.4 VAC	RANGE	
40 TO 110 MA	INPUT CURRENT	
: 0° TO +55°C	TEMPERATURE	ENVIRONMENT
0.9 TO 2.7 W	POWER LOSS	
-40°C TO +70° C	STORAGE	
ALTERNATIVE POWER	TYPE	INPUT
24 VAC	VOLTAGE	
RELAY OUTPUTS, DRY CONTACTS	TYPE	OUTPUTS
MAX 10 A PER RELAY	CONTINUOUS CURRENT	

## VI. CONCLUSION

In this paper many aspects regarding to auto changeover system using PLC are presented. This paper presents result of prototype model regarding to auto changeover system which helps in increasing system stability and speed of operation which improves reliability. This project helps in replacing the conventional controlling system with the newer technology which further helps in eliminating the manual switching.

## REFERENCES

- [1]. *International journal of advanced research in electronics and communication engineering (ijarece)* volume 5, issue 4, april 2016, “Auto changeover from mseb to dg set and vice versa by using PLC.
- [2]. *International Journal of digital application & contemporary research* (volume 4, issue 3, october 2015), “a review of automatic switching by using plc system”.
- [3]. J. F. Gieras, P. D. Hartzenberg, I. J. Magura, and m. Wing, —control of an elevator drive with a single-sided linear induction motor, in proc.5th eur. Conf. Power electronics and applications, vol. 4, 1993, p.p. 353–358.
- [4]. M. G. Ioannides, P. J. Papadopoulos, and J. A. Tegopoulos, —digital techniques for ac voltage regulation, in proc. 6th int. Conf. Power electronics motion control, budapest, hungary, 1990, p.p. 975–979.
- [5]. J. Crispin, —programmable logic controllers and their engineering applications”, 2nd ed. New york: mcgraw-hill, 2004, 150-155.
- [6]. N. Aramaki, y. Shimikawa, s. Kuno, t. Saitoh, and h. Hashimoto, —a new architecture for high-performance programmable logic controller, in proc. 23rd int. Conf. Industrial electronics, control and instrumentation, vol. 1, 2000, p.p. 187–199.
- [7]. L. Hristofovou and K. Hatzipetvou, —system with plc for the control of asynchronous motor, diploma work, national tech. Univ., athens, Greece
- [8]. M. G. Ioannides and I. M. Katiniotis, —laboratory of electric drives”. Athens, greece: editions national tech. Univ., 2000.
- [9]. Switches- changeover and transfer switches by ABB.