



Environmental Impact of Electricity Generation on Indian Ecosystem

Pallavi Gajbhiye, Taruna Jain** and P. N. Shukla****

*Department of Electrical and Electronics,
Barkatullah University Institute of Technology,
Barkatullah University, Bhopal (Madhya Pradesh), INDIA*

(Corresponding author: Pallavi Gajbhiye)

(Received 25 May, 2018 Accepted 25 July, 2018)

(Published by Research Trend, Website: www.researchtrend.net)

ABSTRACT: The environmental impact of electricity generation is significant because modern society uses large amounts of electrical power which is normally generated at power plants that convert some other kind of energy into electrical power. Thermal & nuclear power plants have been found to affect environmental segments of the surrounding region very badly. Environmental deterioration is attributed to emission of large amount of SO_x, NO_x & SPM & RSPM which disperse over 25 kms radius and cause respiratory and related ailments to human beings and animal kingdom.

As a remedial measure Renewable Energy Source (RES) is an “indigenous” environmental option whose supply is somewhere between 15% and 20% of total world energy demand and some projections indicate that global energy demand will triple by 2050. Therefore, an urgent need of RES is felt worldwide; also it need be formulated as national strategy for the development of renewable energy applications and Energy Conservation Measures (ECM). Solar, Wind & Tidal energy are beneficial compared to conventional energy sources for electricity generation as they are associated with the advantages like low or zero emission of pollutant gases, most abundant and omnipresent, inexhaustible resources, less operational and maintenance cost, and easy availability. This paper suggests RES like solar, wind & tidal to be used as power generation systems to reduce harmful impact of electricity generation on ecosystem.

Key words: Renewable Energy System, thermal & nuclear power generation, solar, wind & tidal energy generation.

I. INTRODUCTION

At present, India is a large consumer of fossil fuels [1]. According to present energy consumption rate, coal reserves should last for about 200 years, oil for approximately 40 years and natural gas for 60 years. Energy demand is increasing day by day because of increasing population and also industrialization. Therefore, it increases the concern towards the global warming, which creates the need of an alternate energy source [2] & also as it is a critical stage of energy crisis, where RES overcomes the increasing power demand [3]. It is needed because of limited resource of fossil fuel or the exhausting traditional energy resources and the soaring cost of fuel & therefore the continuous and fast effort to develop more attracting systems with low-cost, high-performance and multifunction's are required [4].

RES are generally located in geographically remote and demographically sparse areas, Solar, Wind & Tidal are world's fastest growing systems among them [4, 6]. They are uncontrollable sources and their energy output is converted into electricity and sent to load or easily

stored in battery bank or Energy Capacitor System (ECS). These sources can meet the daily load fluctuations in combination with battery bank or other form of energy storage as their power output fluctuate on hourly or daily basis [4, 5, 8].

RES are environmentally beneficial because they have low or zero emission of pollutant gases, abundant and omnipresent nature, inexhaustible sources, less operational and maintenance cost and easy availability [1,3,4,6]. Similarly, another source of energy human can safely predict and be sure of on this planet, is the potential energy of the tides as rise and fall of tides is more cyclic. Tides play an important role in the formation of global climate as well as the ecosystems for ocean habitants. Tidal Energy has the potential and prospect to find a place in the power industry. But with the conventional power plant technology being well established and continued to be in the main stream, tidal power plants are yet to gain commercial acceptance. The conventional energy sources for many countries are almost at their peaks.

Depletion of primary power sources will inevitably force people to replace most of the traditional energy sources with renewable energy in the future. Tidal energy is one of the best candidates for this approaching revolution [7].

II. ENERGY OVERVIEW

Any physical activity done by human or by nature on this earth is caused due to the flow of energy in one form or the other. Energy is the most basic infrastructure input required for economic growth and development of a country.

In 1973 Organization of Petrol Exporting Countries (OPEC founded in 1960) put an embargo on oil production and started an oil pricing control strategy. Oil prices shot up four folds causing severe energy crisis the world over. The world took this shock very seriously and for the first time a need for developing alternative sources of energy was felt and for this, huge fund were allowed. Thus, 1973 is considered as the year of the first ‘oil shock’ and two more in series, in 1979 and 1990 which further focused the attention on alternate energy sources compared to conventional energy sources, both listed in Table 1.

Table 1: Classification of energy resources.

Based on usability of energy	Based on traditional use	Based on long term availability	Based on commercial application	Based on origin
<ul style="list-style-type: none"> • Primary resources • Intermediate resources • Secondary resources 	<ul style="list-style-type: none"> • Conventional resources • Non-Conventional resources 	<ul style="list-style-type: none"> • Non-Renewable resource • Renewable resource 	<ul style="list-style-type: none"> • Commercial energy resource • Non-Commercial energy resource 	<ul style="list-style-type: none"> • Fossil fuels energy • Nuclear energy • Hydro energy • Solar energy • Wind energy • Biomass energy • Geothermal energy • Tidal energy • Ocean Thermal energy • Ocean Wave energy

In Fig.1, the heavy dependence on fossil fuels stands out clearly. About 87% of the world’s energy supply comes mainly from fossil fuels. The share of fossil fuels is more than 90% in case of India.

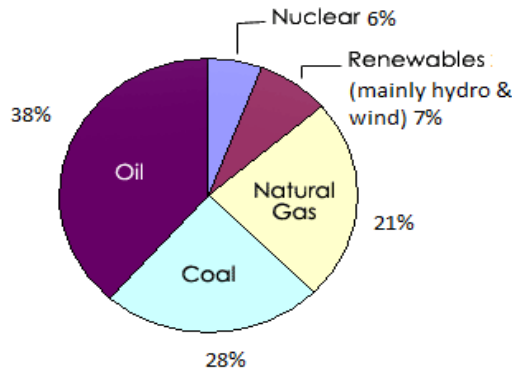
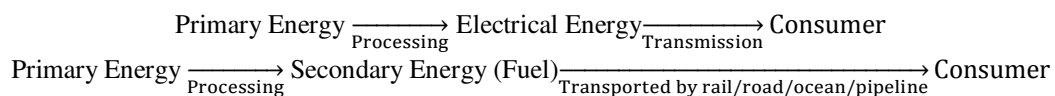

Fig. 1. Percentage consumption of various primary energy resources.

Generally but not always the energy available from the primary energy source known as raw energy is not directly used e.g. electric motor is not directly driven from uranium or coal therefore this energy undergoes

through various transformations and the sequence of this energy transformation between primary and secondary energy as shown in Fig.2., is known as energy chain or energy route expressed as-



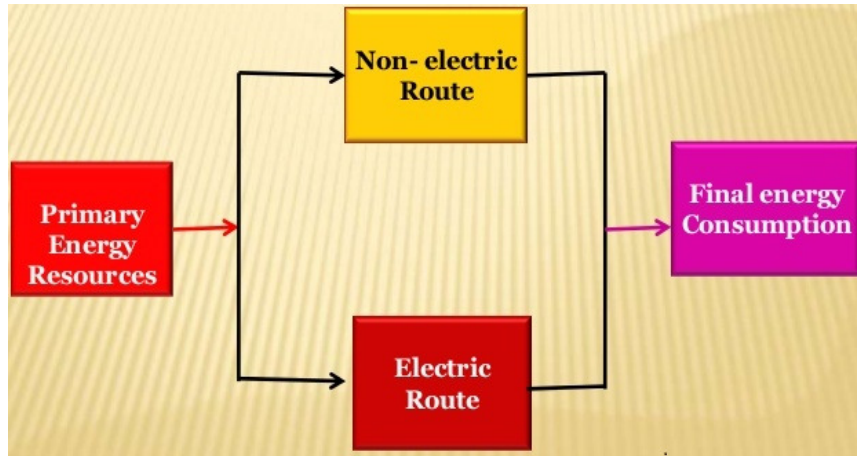

Fig. 2. Energy routes.

At present about 30-40 % of worlds energy supply is met through electrical energy route. As on date, more than 100000 off-grid Solar Photo Voltaic (SPV) systems & around 30000 Wind Turbines (WTs) are installed all over the world [8].

III. PV SYSTEM

Solar energy is clean and renewable, its decentralized character is appropriate well at the scattered state of zones with low density of population. It can be utilized in two ways-

- By collecting the radiant heat and using it in a thermal system or
- By collecting and converting it directly to electrical energy using PV system

The former is referred to as solar thermal and the later as solar PV system.

PV cells are commonly known as solar cells and were first produced in 1954 [9]. They transform sunlight directly into electricity without generating any air or water pollution [1]. They are electronic devices, based on semiconductor technology that governs diodes and transistors.

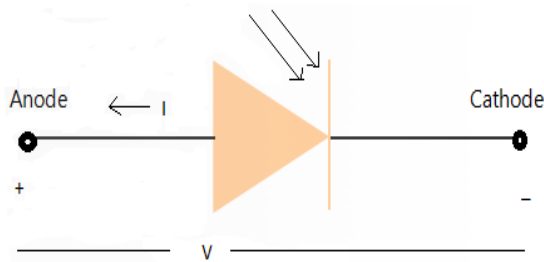

Fig. 3. Schematic symbol of PV cell.

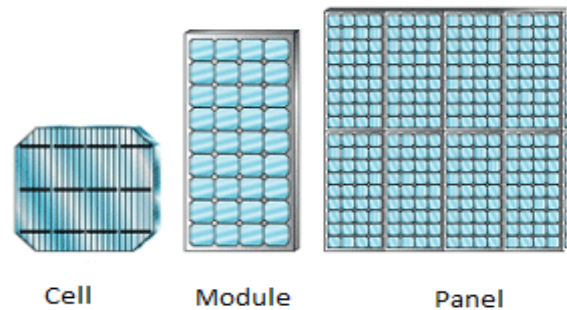

Fig. 4. Cell, module and panel.

A typical commercial cell of 100 sq. cm. area, produces a current of 2A and has a life span in excess of about 20 years.

The schematic symbol of a solar cell with standard sign convention for voltage and current is shown in Fig. 3. A bare single cell cannot be used for outdoor energy generation by itself. It is because-

- Output of a single cell is very small.
- It requires protection (capsulation) against dust, moisture, mechanical shocks and

Outdoor harsh conditions.

Therefore, dozens of PV cells are interconnected together in a sealed and weatherproof package to get workable voltage and reasonable power then their utility is increased and known as solar module- a basic building block of a PV system. At present, the best silicon PV module has efficiency of over 18%, and it is expected that in about 10 years of time, module efficiencies raise to 25% [10].

The series or parallel combination of modules in a frame can be mounted on a structure, known as solar PV panel. Its output power begins from zero at sunrise, rises to a peak at noon time, and returns to zero at sunset [11].

If a large number of interconnected solar panels are installed in an array field then it is known as solar PV array. It is important to ensure that for PV array, a direction without any obstacles facing the sun is needed. The layout and mechanical design of array like tilt angle of panels, height of panels, clearance among the panels etc. are carried out taking into consideration the local climatic conditions, ease of maintenance etc.

Solar PV systems may be structured as -

1. Central power station system
2. Distributed system-
 - a) Stand-Alone system
 - b) Grid-interactive system
 - c) Small system for consumer applications

applications

The total development of solar PV system has exceeded 151 MW, ranking India in 4th place in the world after Japan, USA and Germany. The benefits associated with solar power may be enumerated as -

- Solar energy is directly converted into electrical energy without any thermal-mechanical link.
- Almost at every place Sun radiation is present therefore it is not location specific or it can be located at the place of use (highly mobile and portable), hence no distribution network is needed.
- Solar energy (Sun light) is free of cost therefore there is no operational cost and are easily reliable, durable and highly modular hence, plant economy is not a strong function of size.
- It is more flexible, easy to operate therefore short lead time to design, install and start up a new plant.
- No machinery or moving parts (static structure) therefore low maintenance and repairing needed.

- It consumes no fuel therefore not polluting the environment and is eco-friendly.
- It has wide power handling capability and has high power to weight ratio.
- Its output power matches very well with peak load demands.
- Only some cleaning of upper surface of module is needed occasionally for proper working.
- These systems are quiet compatible with almost all environments, respond instantaneously to solar radiation and have an expected life span of 20 years.

IV. WIND TURBINE SYSTEM

Wind Turbine is a device which converts kinetic energy from wind into mechanical energy and the process is known as wind power. Wind power is basically electricity produced by generator and which is driven by a turbine according to flowing air's aerodynamics. For WT, appropriate wind speed and direction are the key elements and it should be subjected to non-turbulent wind and mounted higher than trees and other obstacles. Wind turns the blades, which spin a shaft, which is connected to a generator and produces electricity. Single small turbines (below 50 KW) are used in homes, telecommunication dishes and water pumping [9]. No speed control, yaw and tilt control, pitch control & stall control are some speed control strategies implemented in WTs.

Wind turbines are broadly classified as -

1. **Horizontal Axis Wind Turbine (HAWT)** - with axis of rotation parallel to the air stream
 2. **Vertical Axis Wind Turbine (VAWT)** - with axis of rotation perpendicular to the air stream
- Power-speed characteristics of a WT have four separate regions as shown in Fig.5.

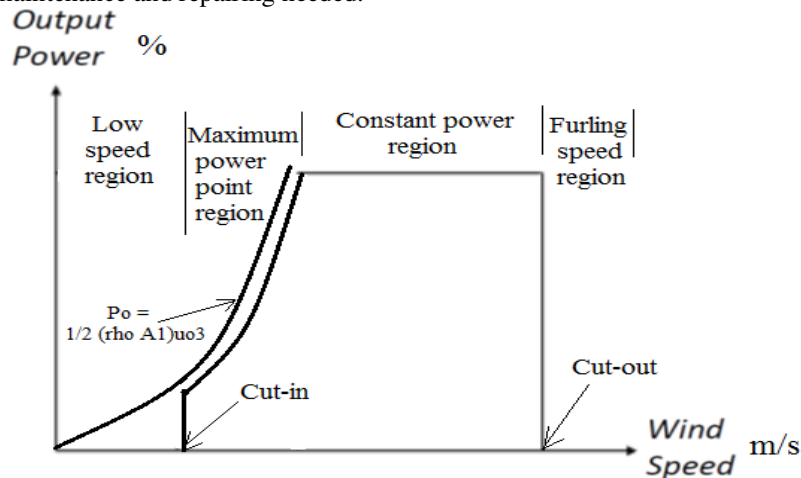

Fig. 5. Power versus wind speed characteristics.

In Low speed region (zero to cut-in speed) turbine is in braked position till minimum wind speed (5 m/s) called as cut-in speed becomes available. **In Maximum power coefficient region**, rotor speed is varied with wind speed to operate it at constant tip-speed ratio, corresponding to maximum power coefficient $C_{P\text{ MAX}}$. **In Constant power region (constant turbine speed region)** during high speed wind (above 12 m/s), rotor speed is limited to upper permissible value based on design limits of the system components. **In Furling speed region (cut-out speed and above)** beyond certain maximum value of wind speed (25 m/s) rotor is shut down and power generation is stopped to protect the blades, generator and other components of the system.

A. Wind Energy Conversion System (WECS)

It converts wind energy into some form of electrical energy. Speed of turbine shaft is stepped up with the help of gears, with fixed gear ratio, to suit the electrical generator and fine-tuning of speed is

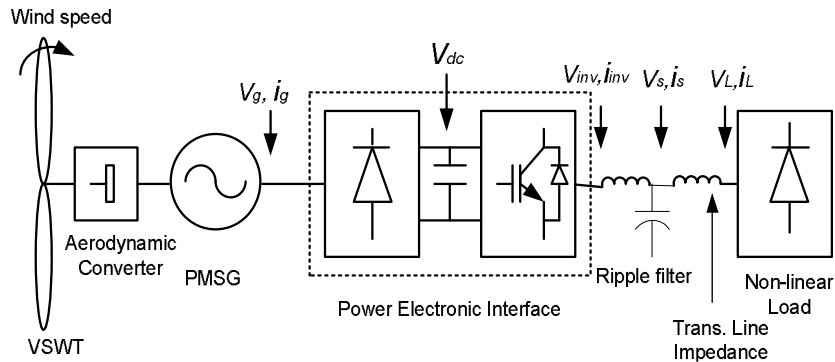

Fig. 6. General Block diagram of WECS.

2. Variable speed drive scheme- Rotor speed is allowed to vary optimally with the wind speed to capture maximum power. It can capture one third more power per year as compared to fixed speed drive system.

Wind power program in India was initiated in 1983-84 and India stands 5th in the world among countries having large installed capacity WTs (after Germany, Spain, USA and Denmark) and providing expertise to Turkey, Egypt and Philippines. Following benefits of wind power are enumerated over other forms of energy

- Wind is available in ample, therefore it can be captured efficiently.
- WTs can be very tall, each takes up only a small plot of land, so the land below it can still

be used and it is especially the case in agricultural areas as farming can still continue. It replaces electricity from coal-fired power plants and thus reduces greenhouse gases, which produce global warming.

incorporated by pitch control. This block acts as drive for generator. DC, synchronous or induction generators are used for mechanical to electrical power conversion depending on the design of the system. Interface block conditions the generated power to grid quality power. It consists of power electronic converter, transformer and filter. Control unit monitors and controls the interaction among various blocks. It derives reference voltage and frequency signals from the grid and receives wind speed, wind direction, WT speed signals etc. process them and accordingly controls various blocks for optimal energy balance.

Two schemes are developed for the operation of WECS on the basis of generator drive-

1. Fixed speed drive scheme- Constant speed is maintained at the shaft of generator by pitch control. A synchronous or induction generator is used to generate electrical energy and induction generator is gaining more acceptability due to its ability to absorb small variations in shaft speed.

V. TIDAL ENERGY SYSTEM

Tidal power or tidal energy is a form of hydropower which converts the energy obtained from tidal waves into useful forms of power, mainly electricity. Its use is originated in around 900 AD when early civilizations constructed tide mills. These mills used the force of the tide to turn a waterwheel, which in turn was used to grind grain into flour. Britain and France are using the tidal power concept since 11th century for milling grains. The world's first large-scale tidal power plant became operational in 1966.

A. One Way Tidal Power Generation System

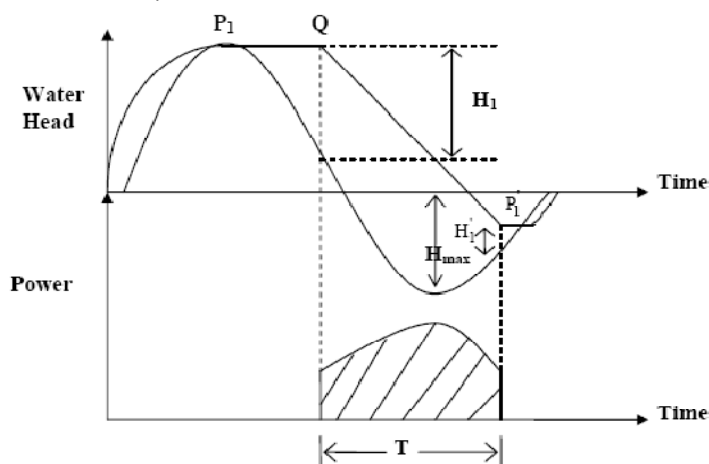

Fig. 7. One Way Tidal Power Generation System.

In one way tidal power generation system one way turbine is used, tidal power is generated by both sea water level and the river basin water level. From Fig.7 it is clear that sea water level is varying approximately sinusoidal. During high tide basin water level will follow sea water level very closely because sluice gates are open. If sea and basin water levels are equal at point P1, both sluice gates and turbines are closed. It will be closed until a sufficient head H_1 built up. If heads built up sluice gates at point Q will be open and the basin water level will fall with duration of T. At point P1' there is not sufficient head H_1 is present to produce electricity. As a result both turbine and sluice gates will

be closed until the two levels are equal. The moment these two levels are equal again then next cycle will start. Hence total power generation duration will be T. The advantage of this kind of plant is only one turbine is required for the plant and the cost of the turbine, operation and maintenance are low. Turbine model required for this kind of plant is also industrially available. However, the disadvantage of this plant is the amount of power produced is less. Apart from its demerits this kind of power plant is widely used.

B. Two Way Tidal Power Generation System

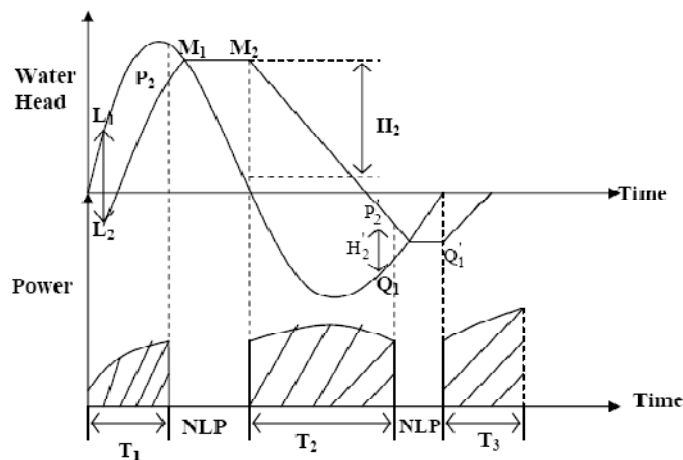

Fig. 8. Two Way Tidal Power Generation System.

Fig. 8 shows the water flow and position of the turbines, basin water level & sluice gates. During high tide water will go through the turbine and therefore there should be a difference between the points L1 and L2. Water is passing into the basin from sea eventually basin water level will up. It will be rising until it reaches at point P2 and a sufficient head build up.

At point P2 sluice gates will be open but turbines are closed until the basin and sea water levels are equal at point M1. At point M2 a sufficient head will build up for power generation and then at point M2, turbines will open in opposite direction and basin water level will fall.

The dive will last until it reaches at point P2'. While there is not enough sufficient head to produce electricity (up to H2'), turbines will be closed but sluice gates are open still at point Q1. The moment they are equal and will be equal at point Q1' sluice gates will be closed. After building the next head H2' sluice gate opens and new cycle begins. From the power output curve it is seen that power duration will be T1, T2 and T3. This obviously illustrates power generation will be higher compared to previous power generation regime. However, two way tidal power generation system has the capability to produce larger amount of electricity which actually attracted the researcher to treat this method as a viable option to ensure the energy security.

VI. CONCLUSION

This paper includes the relevant papers on design, modeling, control and optimization of renewable energy generation techniques, which helps to review that the most frequent systems are made up of PV system and/or WT system and/or Tidal system where solar and wind generation systems are the main power generation devices which improves the stability of the entire system.

The systems in which accuracy, cost and time are important the role of RES become efficient and economical & is a good option for 24 hours load for base load and also for critical loads under varying weather conditions with minimum cost in rural and remote areas. All the key factors are in equilibrium and also there is an optimum combination between the three factors: energy, ecology and economy. If compared to any fossil fuel based power system then the running cost of this system is very low if installed in proper location. Power fluctuation in power generated by individual PV, WT & Tidal systems is dependent on environmental factor. This power fluctuation is suppressed by battery and is the subject of future work.

REFERENCES

[1]. R. Sankarganesh and S. Thangavel, "Maximum Power Point Tracking in PV System using Intelligence based P&O Technique and Hybrid Cuk Converter", *Proceedings of*

International Conference on Emerging Trends in Science, Engineering and Technology, IEEE 2012.

[2]. A.M. Zaki, S. I. Amer and M. Mostafa, "Maximum Power Point Tracking for PV System Using Advanced Neural Networks Technique", *International Journal of Emerging Technology and Advanced Engineering*, vol. 2, issue 12, pp. 58-63, Dec-2012.

[3]. M. Suresh and Yerra Sreenivasa Rao, "Maximum Power point Tracking in Hybrid Photo-voltaic and Wind Energy Conversion System", *Proceedings of International Journal of Engineering Research & Technology (IJERT)*, vol. 1, issue 5, July-2012.

[4]. Nabil A. Ahmed and Masafumi Miyatake "A Stand-Alone Hybrid Generation System Combining Solar Photovoltaic and Wind Turbine with Simple Maximum Power Point Tracking Control", *IEEE* 2006.

[5]. P. Pradeep and B. Kiran Babu, "Power-Management Strategies for a Grid-Connected PV-FC Hybrid System By Using Fuzzy Logic Controller", *Proceedings of International Journal of Modern Engineering Research (IJMER)*, vol. 2, issue. 2, pp-358-364, Mar-Apr 2012

[6]. Ajay Kumar Bansal, Rajesh Kumar and R. A. Gupta, "Economic Analysis and Power Management of a Small Autonomous Hybrid Power System (SAHPS) Using Biogeography Based Optimization (BBO) Algorithm", *IEEE Transactions on Smart Grid*, vol. 4, no. 1, March-2013.

[7]. Tausif Ali, Muhammad Omar Faruk, Sabuj Das Gupata, "Tidal Power: An Option for Alternative Sustainable Power Generation in Bangladesh", *International Journal of Scientific and Research Publications*, Vol. 2, Issue 10, Oct 2012.

[8]. A.H. Shahirinia, S.M.M. Tafreshi, A. Hajizadeh Gastaj and A.R.Moghaddamjoo, "Optimal Sizing of Hybrid Power System Using Genetic Algorithm".

[9]. Aparna Pachori and Payal Suhane, "Modeling and Simulation of Photovoltaic/Wind/Diesel/Battery Hybrid Power Generation System", *International Journal of Electrical, Electronics and Computer Engineering (IJECE)*, vol. 3, issue 1, pp. 122-125, 24th May 2014.

[10]. Rakesh Gurjar and Amita Mahor, "Renewable Energy: Solar-Wind Hybrid System Power Supply For Telecommunication Sector" *VSRD International Journal of Electrical, Electronics & Communication Engineering*, vol. 3, pp. 2.

[11]. Bogdan S. Borowy and Ziyad M. Salameh, "Optimum Photovoltaic Array Size for a Hybrid Wind/PV System", *IEEE Transactions on Energy Conversion*, vol. 9, no. 3, September-1994.