



## **Design and Development of Gas Analyzer for Detecting Ammonia, NO<sub>2</sub>, CO and CO<sub>2</sub>**

*Shivaraj, Sujata Naduvinamani, P. Soumya, D. Shriya and Sourabh*

*Department of Instrumentation Technology, BVB, Hubli, INDIA*

*(Corresponding author: Shivaraj)*

*(Published by Research Trend, Website: [www.researchtrend.net](http://www.researchtrend.net))*

**ABSTRACT:** The main objective of this work is to design and develop gas analyzer for detecting the gas molecules like Ammonia NO<sub>2</sub>, CO, CO<sub>2</sub> present in the Gas chamber. Metal oxide semiconductor gas sensors are utilized in a variety of different roles and industries. They are relatively inexpensive compared to other sensing technologies, they are robust in nature, lightweight, long lasting and its sensitivity is very high and better response. They have been used extensively to measure and monitor small traces of gases present in the environment such as ammonia, carbon monoxide, Carbon dioxide and nitrogen dioxide. In this paper the nature of the gas response and how it is sensed by the sensors and how there is change in the sensor response is experimentally found. The metal oxide semiconductor gas sensors are also discussed sensors for the detection of a variety of gases—CO, CO<sub>2</sub>, NO<sub>2</sub>, NH<sub>3</sub>.

**Keywords:** Ammonia sensor, signal sensing, Gas sensor, CO, CO<sub>2</sub>, NH<sub>3</sub>, NO<sub>2</sub>

### **I. INTRODUCTION**

A sensor is a technological device that detects / senses a signal, physical condition and chemical compounds.

Gas sensor is a subclass of chemical sensors. Gas sensor measures the concentration of gas in its vicinity. It interacts with a gas to measure its concentration. It must possess at least two functions: (i) to identify a particular gas and (ii) convert the output into measurable sensing signals

The necessity to constantly monitor and control the gases emitted, burgeoned the need for gas sensors. Gas sensors have a great impact in many areas such as environmental monitoring, domestic safety, public security, automotive applications, air conditioning in airplanes, space crafts and houses, sensors networks etc. Unmonitored gas rapidly becomes hazardous. Certain gases are corrosive, explosive or can be toxic for human

beings. For these reasons, different gas sensor technologies exist.

### **METHODS**

Gas sensing technologies can be categorized into two groups: methods based on variation of electrical properties and other properties, as shown in Fig. 1.

*A. Methods Based on Variation of Electrical Properties*  
**Metal Oxide Semiconductor.** These are the most common sensing materials. Sensors based on metal oxide semiconductors are mainly applied to detect target gases through redox reactions between the target gases and the oxide surface [1]. Metal oxides such as SnO<sub>2</sub>, CuO, Cr<sub>2</sub>O<sub>3</sub>, V<sub>2</sub>O<sub>5</sub>, WO<sub>3</sub> and TiO<sub>2</sub>, can be employed to detect combustible, reducing, or oxidizing gases with sensors which are mainly based on the resistance change responses to the target gases [2].

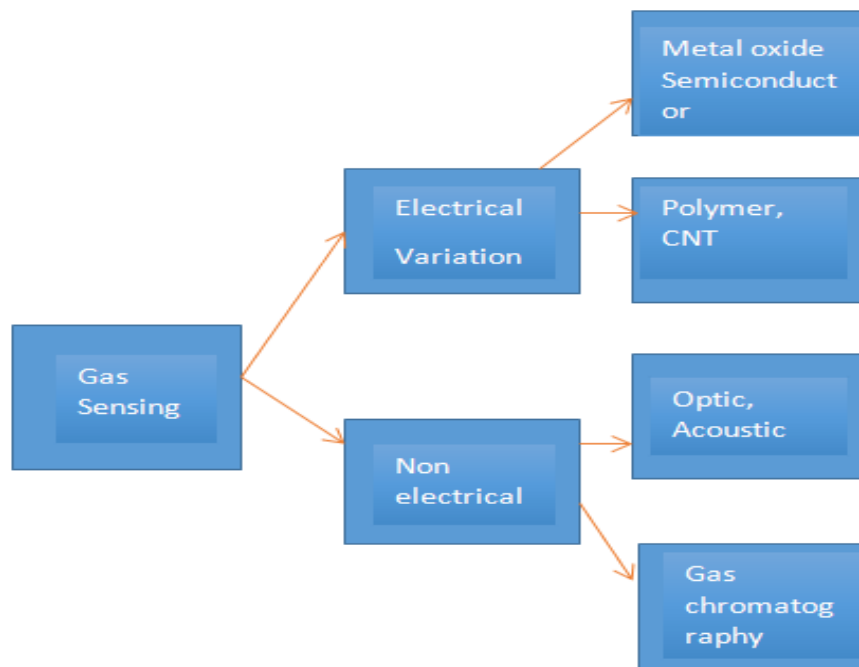

**Fig. 1.** Gas sensing methods.

In this project, we have considered gas sensors where in gas sensing method is based on electrical variation with different materials (Metal oxide semiconductor)

**Polymers.** Polymer-based gas sensing materials are used in detecting inorganic gases like CO<sub>2</sub> and H<sub>2</sub>O [3], they are often used to detect a wide range of VOCs (Volatile Organic Compounds) or solvent vapours in the gas phase, such as alcohols, aromatic compounds or halogenated compounds. Based on the different changes in physical properties, polymers used for gas sensing can be further classified into two groups: (1) conducting polymers, and (2) non-conducting polymers.

**Carbon nanotubes.** Carbon nanotubes (CNTs) are highly sensitive to extremely small quantities of gases, such as alcohol, ammonia (NH<sub>3</sub>), carbon dioxide (CO<sub>2</sub>) and nitrogen oxide (NO<sub>x</sub>) at room temperature, while other materials like metal oxides require an additional heater in order to operate normally. CNTs could also be incorporated into other sensing materials such as metal oxide semiconductors to improve their sensitivity [4].

**Moisture Absorbing Material.** Moisture absorbing materials are used for detecting concentrations of water vapour. Other applications include detecting humidity levels, like water vapour concentration monitoring for food storage, could also utilize methods like those

based on moisture absorbing materials and RFID tags. The moisture-absorbing material enveloped tags are low cost and suitable for mass production, thus more research in this area can be anticipated.

#### *B. Methods Based on Variation of Other Properties*

**Optic Methods.** Optic methods monitor the optical absorption, emission and scattering of a gas species at definite optical wavelengths. The distribution of this optical absorption or emission with wavelength provides an optical 'fingerprint' for any gas species nearby, and the magnitude typically shows the concentration. Optical methods for gas sensing are based on spectroscopy, Ellipsometry and Interferometry.

**Acoustic Methods.** Sound based gas sensors are known as acoustic wave based gas sensors. To generate the acoustic waves, this type of sensor use piezoelectric material either in the thin film form or in bulk form which has one or more transducers on its surface. Acoustic impedance is usually used to determine gas density, since the acoustic impedance is given by the simple equation:  $Z = \rho C$ , where  $\rho$  is the gas density and  $C$  is the sound speed. Thus, by the measured acoustic impedance and sound speed, the density of a gas could be calculated [5].

**Gas Chromatograph.** Gas Chromatography (GC) is one of the common methods for gas sensing. The purpose of the Gas Chromatograph is to separate mixtures into individual components that can be detected and measured one at a time. It is widely used for quantitative and qualitative analysis of mixtures, purification of compounds, monitoring of industrial processes.

Many routine analyses are carried out rapidly in environmental and other fields. For example many countries have fixed monitor points to continuously measure the emission levels of nitrogen dioxides, carbon dioxide and carbon monoxide.

**Calorimetric Methods.** Calorimetric gas sensors detect the change of temperature  $\varphi T$  of the active surface layer, made of, e.g., poly-siloxane derivatives due to adsorption or a chemical reaction (*pellistors*) of the gas molecules at the surface layer. The principle of calorimetric gas sensors based on change in temperature at catalytic surfaces. It consists of a surface of a film of a catalytically active metal (e.g. Platinum, Palladium or Rhodium). It burns combustible gases. Heat is generated due to the combustion. This heat is balanced by a reduction in the electrical heating power. Thus the power consumption indicates the concentration of gas.

Sensing technology has been widely investigated and utilized for gas detection. Due to different applicability and inherent limitations of different sensing techniques, common applications are in the following areas:

- Industrial Production.(Example: Methane detection in mines)
- Automobile Industry.(Example: Detection of gases from vehicles)
- Medical Industry.(Example: Electronic noses)
- Environmental Studies.(Example: Greenhouse gas monitoring).

#### **Types of gas sensors**

Various gas sensors are used for detecting the different gas molecules present in the atmosphere.

#### **1. Carbon Monoxide Sensors**

Carbon monoxide (CO) is produced when carbon-based fuel is burnt incompletely and is poisonous at higher concentrations. It is a colorless and odorless gas which is undetectable to humans. High concentration of CO affects human health. It causes Headache, dizziness, nausea, tachycardia etc. Sensors have been utilized by researchers to actively measure the varying concentration of CO in the environment.

Carbon monoxide gas sensors have a myriad of applications, such as home safety, measuring atmospheric concentrations, exhaust of cars, and for monitoring of processes in industrial plants.

#### **2. Carbon Dioxide Sensors**

Carbon dioxide (CO<sub>2</sub>) is a greenhouse gas which is produced when fuel containing carbon is burnt and it contributes to global warming. Carbon dioxide has many uses: carbonating drinks, pneumatic applications, fire extinguishers, photosynthesis, lasers and refrigerants are just some examples where carbon dioxide has found a use, by nature and by humans. Carbon dioxide can cause substantial negative health affects to humans including headache, drowsiness, Unconsciousness, convulsions, sweating, restlessness etc.

A number of different metal oxide semiconductor materials have been investigated for the detection of carbon dioxide including ITO, SnO<sub>2</sub>, BaTiO<sub>3</sub> and LaOCl. Of these LaOCl has the best performance.

#### **3. Nitrogen Oxide (NOx) Sensors**

Oxides of nitrogen (NO<sub>x</sub>) are produced in the combustion chamber of engines at high temperatures. NO<sub>x</sub> reacts with hydrocarbons in sunlight and produce ozone and photochemical smog. NO<sub>x</sub> can contribute to respiratory illnesses and acid rain. Animal subjects subjected to long-term exposure of NO<sub>2</sub> were found to have damaged lungs [6,7].The monitoring of the concentrations of NO<sub>x</sub> in the air can be particularly useful, as environmental agencies can use it to anticipate how likely smog is to form and alert the public at times of substantial risk.WO<sub>3</sub> is the broadly used material for the detection of nitrous oxides typically NO<sub>2</sub> and NO. It provides the largest response to NO<sub>2</sub> of all MOS materials with minimal cross sensitivity and it finds use in many commercial products.

#### **4. Ammonia Sensors**

Ammonia (NH<sub>3</sub>) is a dangerous colorless gas with a characteristic pungent odour. Ammonia is present in animal waste, in vital biological molecules such as amino acids (the building blocks of proteins) and is a source of nitrogen to living organisms. In agricultural environments, where animals live in unventilated environments, ammonia concentrations can become high enough to kill the animals. Hence an ability to monitor and control these environments is highly desirable.

The materials used for the detection of ammonia gas are ZnO, WO<sub>3</sub> and TiO<sub>2</sub>.

#### **Objectives and Implementation methodology**

The main objective of this paper is focused for the environmental ailments that the society is facing. On a daily basis we inhale many dangerous gases like CO, CO<sub>2</sub>, NO<sub>2</sub>, and NH<sub>3</sub> from the exhaust of the vehicles, industries, laboratories and dump yard it's in turn affecting the health of human and animals.

With this concern we are designing and developing the smart gas analyzer system which will detect the small traces of the gas molecules present in the specified area. The main aim is to detect the particular gas present in the area under the test, and continuous monitoring of the gas compositions present in it. Controlling of the particular gas if it is required. The proposed smart gas analyzer system includes the multiple sensors like ammonia ( $\text{NH}_3$ ), carbon-monoxide (CO), carbon-di-oxide ( $\text{CO}_2$ ), nitrogen-di-oxide ( $\text{NO}_2$ ) and the output of the sensor is continuously monitored and controlled if it

is required. Our paper focuses on the online monitoring of various gases like ammonia ( $\text{NH}_3$ ), carbon-monoxide (CO), carbon-di-oxide ( $\text{CO}_2$ ), nitrogen-di-oxide ( $\text{NO}_2$ ). The fig 2. Shows the various sensors like ammonia ( $\text{NH}_3$ ) sensor, carbon-monoxide (CO) sensor, carbon-di-oxide ( $\text{CO}_2$ ) sensor, nitrogen-di-oxide ( $\text{NO}_2$ ) which are used so as to sense the small traces of these gases present in the atmosphere. This smart system can be globally used and thus help in eradicating the problem of consumption of injurious gases.

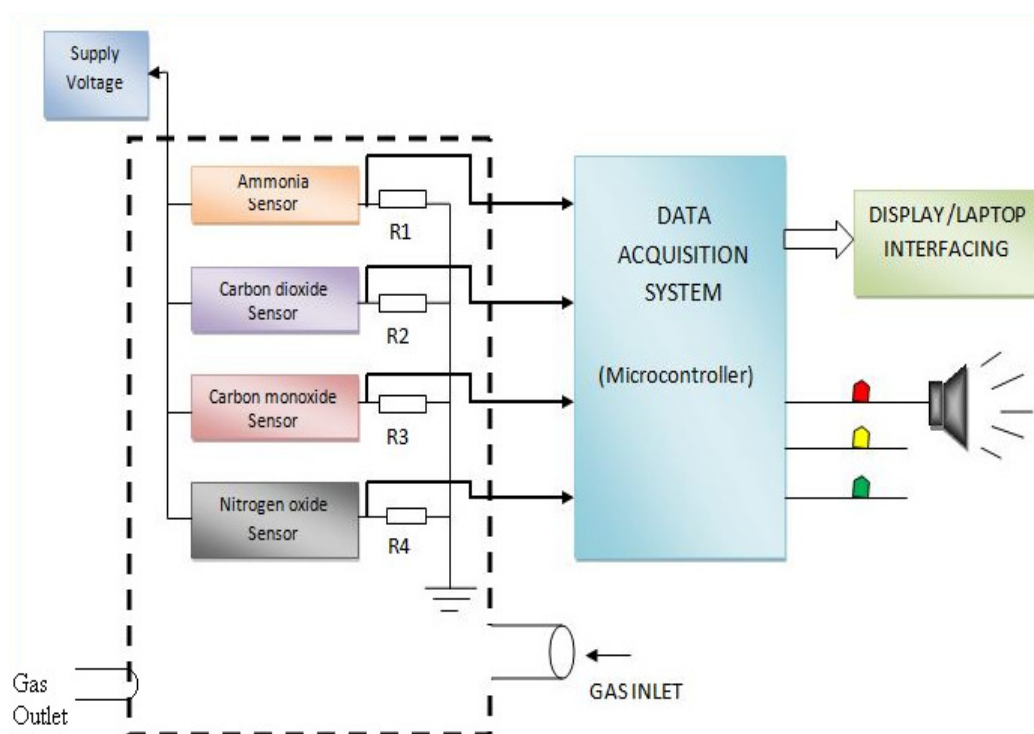

**Fig. 2.** Block diagram of gas sensor using micro-controller.

The proposed system, we can detect the amount of various gases (in parts per million) present in the atmosphere. These sensors are exposed to gas molecules in the environment and when the sensors encounter any of these gas molecules they produce an output which is fed to the micro-controller arduino and the output from arduino is observed through the three LED that will be indicating the amount of the particular gas in the environment. The three LED's red, green, yellow will be observed according to the amount of the gases present. And further the precise amount of the gases present in the environment will be observed in the LCD in terms of Parts per Million (PPM).

## RESULTS AND DISCUSSION

In this work we have carried out the characterization of the Ammonia ( $\text{NH}_3$ ), Nitrogen dioxide ( $\text{NO}_2$ ), carbon monoxide (CO) and Carbon diode ( $\text{CO}_2$ ). The specifications of the sensors are listed in Table 1-4. The gas sensors are placed in the gas chamber, the sensors are exposed to the gases, and the sensors sense the respective gas molecules and produce the electrical voltage as mV. As the output of each sensor is very small it is amplified by amplifier, then the amplified output is analog quantity and is converted to digital with the help of ADC converter, then ADC output is given to the Aurdino controller for the further monitoring and the control of the process.

**Table 1: Electrical Specifications of NH<sub>3</sub>.**

Symbol	Parameter name	Technical condition	Remarks
Vc	Circuit Voltage	5V±0.1	AC or DC
Vh	Heating Voltage	5V±0.1	AC or DC
RL	Load Resistance	Can adjust	
RH	Heater Resistance	33Ω±5%	Room Temp
PH	Heating Consumption	Less than 800mW	

**Table 2: Electrical Specifications of CO<sub>2</sub>.**

Symbol	Parameter name	Technical	Remarks
Vh	Heating voltage	6.0±0.1V	AC or DC
Rh	Heating resistance	30.0±5%Ω	Room Temperature
Ih	Heating current	@200mA	-----
Ph	Heating power	@1200mW	-----
Tao	Operating temperature	-20 to 50	-----
Tas	Storage temperature	-20 to 70	
E	output	30 to 50mV	350-10000ppm

**Table 3: Electrical Specifications of NO<sub>2</sub>.**

Rating	Symbol	Value/Range	Unit
Maximum sensor supply voltage	VCC	2.5	V
Maximum heater power dissipation	Ph	50	mW
Maximum sensor power dissipation	Pb	1	mW
Relative humidity range	Rh	1-95	%RH
Ambient operating temperature	Tamb	-40-125	°C
Storage temperature range	Tsio	-40-125	°C
Storage humidity range	RHsio	5-95	%RH

## CONCLUSION

We have carried out the characterization of ammonia (NH<sub>3</sub>), carbon monoxide (CO), carbon di-oxide (CO<sub>2</sub>), nitrogen di-oxide (NO<sub>2</sub>). The Sensors are placed in the Gas chamber for the detection of the respective gases. Further we need to develop the gas chamber set up and the signal conditioning circuit for handling the data and interfacing sensor data to the Aurdino controller which is interfaced to PC for further monitoring and controlling.

## ACKNOWLEDGEMENTS

We would like to acknowledge our gratitude to Department of Instrumentation Technology, B.V. Bhoomaraddi College of Engineering and Technology, Hubli for supporting this work

## REFERENCES

- [1] Yamazoe, N, Shimano, K. "Theory of power laws for semiconductor gas sensors". *Sens. Actuators B* **2002**, 128, 566–573.
- [2] Batzill, M.; Diebold, U." The surface and materials science of tin oxide". *Prog. Surf. Sci.* 2005, **79**, 47–154.
- [3] Emadi, T.A.; Shafai, C.; Freund, M.S.; Thomson, D.J.; Jayasz, D.S.; Whitex, N.D.G ."Development of a polymer-based gas sensor-humidity and CO<sub>2</sub> sensitivity". In *Proceedings of the 2nd Microsystems and Nanoelectronics Research Conference (MNRC)*, Ottawa, ON, Canada, 13–14 October 2009; pp. 112–115.
- [4] Wisitsoraat, A.; Tuantranont, A.; Comini, E.; Sberveglieri, G. "Gas sensing properties of CNT-SnO<sub>2</sub> nanocomposite thin film prepared by E-beam evaporation". In *Proceedings of 2007 IEEE Sensors*, Atlanta, GA, USA, 28–31 October 2007; pp. 550–553.
- [5] Mylvaganam, S.; Halstensen, M.; Engen, H.; Esbensen, K. "Gas density metering in ultrasonic gasflowmeters using impedance measurement and chemometrics". In *Proceedings of 1999 IEEE Ultrasonics Symposium*, Caesars Tahoe, NV, USA, 17–20 October 1999; pp. 435–439.
- [6] Barth, P.J.; Muller, B.; Wagner, U.; Bittinger, "A. Quantitative analysis of parenchymal and vascular alterations in NO<sub>2</sub>-induced lung injury in rats". *Eur. Resp. J.* **1995**, 8, 1115–1121.
- [7] Wegmann, M.; Fehrenbach, A.; Heimann, S.; Fehrenbach, H.; Renz, H.; Garn, H.; Herz, U. NO<sub>2</sub>-induced airway inflammation is associated with progressive airflow limitation and development of emphysema-like lesions in C57BL/6 mice. *Expt. Tox. Path.* **2005**, 56, 341–350.
- [8] Ashish Shrivastava, Ratnesh Prabhaker, Rajeev Kumar, Rahul Verma, "GSM Based Gas Leakage Detection System", *International Journal of Emerging Trends in Electrical and Electronics (IJETEE – ISSN: 2320-9569)*, Vol. **3**, Issue. 2, May-2013.
- [9] V.Ramya, B. Palaniappan, "Embedded system for Hazardous Gas detection and Alerting", *International Journal of Distributed and Parallel Systems (IJDPSS)*, Vol. **3**, No.3, May 2012.
- [10] Su Baishun, Pang Zhengduo, Meng Guoying, "Design of the mine gas sensor based on Zigbee", *Proceedings of the Third International Symposium on Computer Science and Computational Technology (ISCSCCT '10)* Jiaozuo, P. R. China, 14-15, August 2010, pp. 077-081.
- [11] Hoseon Lee, George Shaker, Krishna Naishadham, Xiaojuan Song, Michael McKinley, Brent Wagner, Manos Tentzeris, "Carbon-Nanotube Loaded Antenna-Based Ammonia Gas Sensor", *IEEE Transactions On Microwave Theory And Techniques*, Vol. **59**, NO. 10, OCTOBER 2011.
- [12] L.K. Hema, Dr. D. Murugan, M.Chitra, "WSN based Smart system for detection of LPG and Combustible gases", *National Conference on Architecture, Software systems and Green computing-2013 (NCASG2013)*
- [13] Linhongjia Xiong and Richard G. Compton, "Amperometric Gas detection: A Review", *International Journal of Electrochemicalscience, Int. J. Electrochem. Sci.*, **9** (2014) 7152 – 7181
- [14] Sergey Romyantsev, Guanxiong Liu, Radislav A. Potyrailo, Alexandr A. Balandin, "Selective Sensing of Individual Gases Using Graphene", *IEEE Sensors Journal*, VOL. **13**, NO. 8, AUGUST 2013.