



Comparison of MIMO OFDM System with BPSK and QPSK Modulation

Vijaykumar Katgi

Asst. Prof. Department of Electronic and Communication Engineering, BKIT, Bhalki, INDIA

(Corresponding author: Vijaykumar Katgi)

(Published by Research Trend, Website: www.researchtrend.net)

ABSTRACT: This paper describes a method to design, and simulate adaptive algorithm for system with multiple transmit and receive antennas. The idea is to transmit multiple streams of data on multiple antennas at the same frequency, to increase reliability and throughput. Typically, multiple receiver antennas are used as well, since this configuration achieves high data rates and reliability, multiplied by the number of channels between either ends. This principle is called Multiple Input Multiple Output (MIMO). They are particularly attractive because they do not require any additional transmission Bandwidth, and unlike traditional systems use multi-path interference to their benefit. Orthogonal frequency division multiplexing (OFDM) has become a popular technique for transmission of signals over wireless channels OFDM converts a frequency-selective channel into a parallel collection of frequency flat sub channels. The present work focus on comparison of multi-antenna scheme such as 2x1, 2x2, 4x1 and 4x2 MIMO OFDM System with BPSK and QPSK Modulation , employing Space Time Block coding to get higher reliability. The BER performance comparison charts for a MIMO, 2X1, 2X2, 4X1, 4X2 with BPSK and QPSK Modulation, got by simulation of code using MATLAB and these BER plots are included in the result.

Key words: OFDM, MIMO, STBC STTC

I. INTRODUCTION

Data rates for wireless cellular and local area networks have been steadily increasing in recent years, with an approximate five-fold increase in throughput every four years. With new applications such as wireless multimedia and the replacement of cables for communication purposes in home, office and public access scenarios, we can anticipate this trend to continue. Three challenging requirements arise from the call for higher data rates and reliability in next generation wireless systems: we have to increase spectral efficiency, design systems for larger bandwidths, and we shall reduce the costs per bit as well.

Exploiting the rich scattering typical for indoor and urban environments [1], multiple-input multiple output (MIMO) systems allow for sound gains in the spectral efficiency, thus facilitating the transmission at higher reliability in a spectrum which is usually limited by regulation and other factors.

OFDM owes its origin to Frequency Division Multiplexing (FDM). In FDM, each of the several low rate user signals is modulated with a separate carrier

and transmitted in parallel. Thus the separation of the users is in the frequency domain. OFDM converts a frequency-selective channel into a parallel collection of frequency flat subchannels. The subcarriers have the minimum frequency separation required to maintain orthogonality of their corresponding time domain waveforms, yet the signal spectra corresponding to the different subcarriers overlap in frequency. Hence, the available bandwidth is used very efficiently
Let's compare this parallel transmission scheme with a single high rate data transmission. The results of the comparison are tabulated in Table 1.

Table 1: Comparison of Parallel and Serial Transmission Schemes.

Transmission method	Parallel	Serial
Symbol time	Ts	Ts/N
Rate	1/Ts	N/Ts
Total BW required	$2^N/Ts + N \cdot 0.1/Ts$ (Assume Guard band = 0.1/Ts)	$2^N/Ts$
Susceptibility to ISI	Less	More

Multiple antennas can be used at the transmitter and receiver, an arrangement called a multiple-input multiple-output (MIMO) system. A MIMO system takes advantage of the spatial diversity that is obtained by spatially separated antennas in a dense multipath scattering environment. MIMO systems may be implemented in a number of different ways to obtain either a diversity gain to combat signal fading or to obtain a capacity gain. Generally, there are three categories of MIMO techniques. The first aims to improve the power efficiency by maximizing spatial diversity. Such techniques include delay diversity, space-time block codes (STBC) [4], [5], [7] and space-time trellis codes (STTC) [6]. The second class uses a layered approach to increase capacity. One popular example of such a system is V-BLAST suggested by Foschini *et al.* where full spatial diversity is usually not achieved. Finally, the third type exploits the knowledge of channel at the transmitter.

II. MIMO TECHNIQUES

We will discuss various techniques proposed in an attempt to achieve this capacity

A. Diversity Techniques.

They take advantage of spatial and temporal diversity to combat the random fading induced by multi-path propagation of the signal. Transmit or Receive Diversity is employed depending on use of multiple transmit and receive antennas respectively. Multiple correlated symbols are sent from different transmit antennas at different time intervals to combat fading and to achieve better BER performance.

Space-Time Block Coding. Alamouti's code, one special case of space-time block codes, is probably the simplest form of space-time structure. The orthogonal structure of the transmitted signal decouples the two symbols sent at the same time and the maximum likelihood detection of the 2-D structure is greatly simplified. It has been shown that Alamouti's code gains full diversity for flat-fading channels and achieves system capacity in a 2 X 1 system.

In STBC systems, the same information symbol stream is transmitted from different transmit antennas in appropriate manner to obtain transmit diversity. Simple linear processing is used at the receiver. Coding is performed in both spatial and temporal domains to introduce correlation between signals transmitted for various antennas at various time periods.

Space-Time Trellis Coding. Space-Time Trellis Coding (STTC) has been extensively studied by

numerous researchers. One method for STTC is to use a super set of orthogonal space-time block codes as symbols in a codeword, and use set partitioning for trellis code design. Another method uses unitary transform to expand the STBC code set and also resorts to set partitioning for trellis design.

The major challenge for STTC is that the maximum-likelihood (ML) decoding complexity grows exponentially with the number of transmit antennas. As more transmit antennas are used, the complexity could become a big issue for high-speed real time decoding. Another issue is that the code design becomes more complicated, even with the given criteria; the search for the optimum code is still a problem

B. Spatial Multiplexing

To simplify space-time structure, layering is done where streams of data are independently coded and decoded. Linear interference suppression (nulling) accompanied by decision-directed interference cancellation is used for detection of each stream (layer). To detect the layered space-time structure, the number of receive antennas should be greater or equal to the number of transmit antennas.

Two layered structures are popular. V-BLAST associates each stream to a fixed transmit antenna whereas D-BLAST cyclically changes the association and codewords are dispersed across diagonals in space-time

BLAST Architecture. Bell Labs Layered Space-Time (BLAST) scheme is designed to transmit information over wireless environment using multiple antennas. This is a technique that allows us to increase the transmission rate up to n_T symbols per time slot which is equal to a full multiplexing gain for the system. At the same time it can provide n_R receive diversity but no transmit diversity for uncoded transmitting structure. The complexity of the BLAST receiver increases linearly with the number of transmit antennas but the limitation is that the number of receive antennas should be more than or equal to the number of transmit antennas to make it possible to detect transmitting

symbols $n_R \geq n_T$.

BLAST ENCODERS

In this section we discuss different BLAST encoding structure such as H-BLAST, V-BLAST and D-BLAST.

V-BLAST Encoder. In general blocks that we use for VBLAST and H-BLAST are same and the only difference between them is the order of arrangement. As it can be seen in Fig.2.1, V-BLAST structure, the encoder and interleaving blocks are before the serial to parallel block. In other words, we are doing vertical encoding between different layers of the BLAST. On the other hand, H-BLAST has horizontal encoding for each layer separately (the name comes from here, V-BLAST for vertical encoding compare to H-BLAST for horizontal encoding).

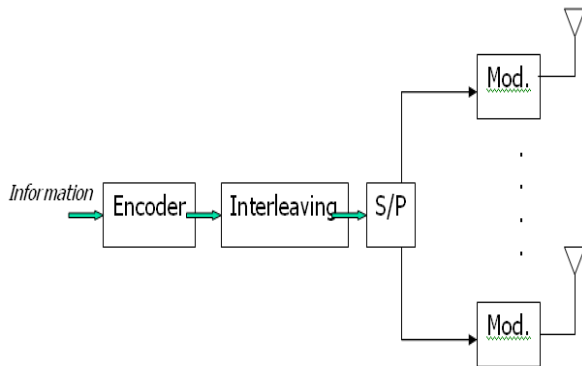

Fig 2.1: VBLAST encoder.

D-BLAST Encoder. Compared to the above encoders, D-BLAST has a more complex encoder and decoder structure.

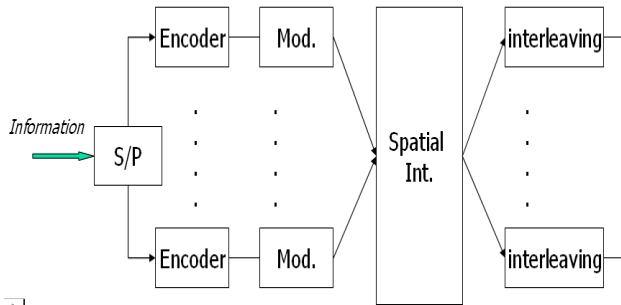

Fig 2.2: D BLAST encoder

D-BLAST is same as H-BLAST with Spatial Interleaver (SI). The task of the spatial interleaver is to spread out the modulated symbols from each layer to all the transmitting antennas. So, all the antennas will transmit for all the layers and that will help the system to avoid deep fades of the wireless channel.

III. MULTI ANTENNA SYSTEMS

One possible way to improve the reliability of wireless communications is to employ diversity. Diversity is the technique of transmitting the same information across multiple Channels to achieve higher reliability. It operates on the principle that it is unlikely that all of the channels used to transmit the redundant information will be experiencing deep fading at the same time. Even if one particular channel is unusable, the information may still be recovered from the redundant transmission over the other channels. Therefore the overall reliability of the communications system is improved, at the cost of transmitting redundant information. If multiple antennas are used at the transmitter or receiver there are potentially multiple transmission channels between the transmitter and receiver. See Figure 3.1 for an example of the potential channels in a 2x2 MIMO system. These multiple channels can be used to exploit diversity.

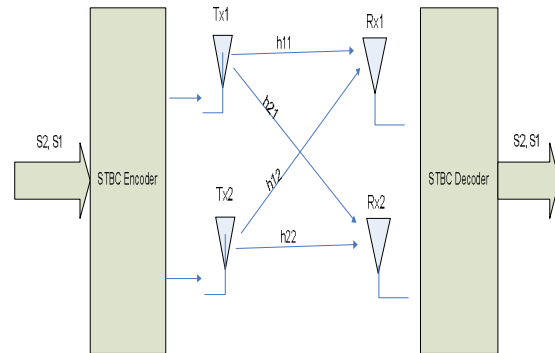

Fig 3.1: Multi Antenna System.

In the 2x2 system in Figure 3.1, there is the potential for both transmit and receive Diversity. Receive diversity is when the same information is received by different antennas. For instance the information sent from Tx1 is transmitted across channels h_{11} and h_{21} and received by both Rx1 and Rx2. Transmit diversity is when the same information is sent from multiple transmit antennas. One possible way to achieve this is to code across multiple symbols periods.

One possible way to achieve this is to code across multiple symbols periods. For instance, at time t antenna Tx1 could transmit the symbol s then at time $t+1$ antenna Tx2 would transmit the same symbol, S . Refer table 3.1.

Table: 3.1. Space-Time Coding Technique.

	Transmitter 1	Transmitter 2
t	S_1	S_2
t+1	$-S_2^*$	S_1^*

The Alamouti scheme uses a method similar to this to obtain transmit diversity. MIMO systems are able to achieve impressive improvements in reliability and capacity by exploiting the diversity offered by the multiple channels between the transmit and receive antennas.

The Alamouti code, so called because it was proposed by S.M Alamouti in [2], belongs to a class of codes called Space-Time Block Codes (STBC).[7]

A. Space-Time Block Coding

Principles of Space-Time (Mimo) Systems. A compressed digital source in the form of a binary data stream is fed to a simplified transmitting block encompassing the functions of error control coding and (possibly joined with) mapping to complex modulation symbols (quaternary phase-shift keying (QPSK), M-QAM, etc.). The latter produces several separate symbol streams which range from independent to partially redundant to fully redundant. Each is then mapped onto one of the multiple TX antennas. Mapping may include linear spatial weighting of the antenna elements or linear antenna space-time precoding. At the receiver, the signals are captured by possibly multiple antennas and demodulation and demapping operations are performed to recover the message. The level of intelligence, complexity, and *a priori* channel knowledge used in selecting the coding and antenna mapping algorithms can vary a great deal depending on the application. This determines the class and performance of the multiantenna solution that is implemented.

Alamouti code. As the name indicates the Alamouti code, was developed by S.M Alamouti, is a special type of Space-Time Block Codes (STBC) and it is coded across space by using multiple transmitter and receiver antennas and time by using multiple symbol periods.

Alamouti space-time block codes are a special class of orthogonal block codes achieving a code rate of 1. The Alamouti code operates on blocks of input bits namely STBC which are represented by a $m \times t$ matrix, where m represents number of transmission antennas and t represents the number of time slots required for transmission of a block.

The matrix shown below represents the functionality of 2 antennas of transmission and one or more antennas of reception.

$$S = \begin{matrix} \begin{matrix} \text{Tx1} & \text{Tx2} \\ \downarrow & \downarrow \end{matrix} \\ \begin{bmatrix} S_0 & S_1 \\ -S_1^* & S_0^* \end{bmatrix} \end{matrix} \begin{matrix} \leftarrow \\ \leftarrow \end{matrix} \begin{matrix} \\ t+1 \end{matrix}$$

The lines of the matrix represent the symbols transmitted by the two sending antennas at the moment T (1st line) and T + Ts (2nd line). Where the matrix identity of order 2 is represented by equation 2.2 below,

$$S^H .S = (|S_0|^2 + |S_1|^2)I_2 \tag{3.1}$$

The orthogonality of S is an important property that has to be taken into account in the development of the space-time decoder.

Expression of the received signal

$$R = S.H + N$$

$$\begin{bmatrix} r_0 \\ r_1 \end{bmatrix} = \begin{bmatrix} S_0 & S_1 \\ -S_1^* & S_0^* \end{bmatrix} \begin{bmatrix} h_1 \\ h_2 \end{bmatrix} + \begin{bmatrix} n_1 \\ n_2 \end{bmatrix} \begin{bmatrix} r_1 \\ r_2^* \end{bmatrix} \tag{3.2}$$

Where, R is a vector of signals received by the 2 sensors with the reception

H represents the matrix of channel

N represents the noise

The criterion of the maximum of probability “ML” leads us to the expressions of the variables of decision on the symbols s_0 and s_1 respectively as shown in the expression 4.3 and 4.4

$$y_0 = h_1^* r_1 + h_2^* r_2^* = (|h_1|^2 + |h_2|^2)S_0 + h_1^* n_1 + h_2^* n_2 \dots(3.3)$$

$$y_1 = h_2^* r_1 - h_1^* r_2^* = (|h_1|^2 + |h_2|^2)S_1 - h_1^* n_2 + h_2^* n_1 \dots (3.4)$$

And in the matrix form it becomes,

$$\begin{bmatrix} y_0 \\ y_1 \end{bmatrix} = \begin{bmatrix} h_1^* & h_2^* \\ h_2^* & -h_1^* \end{bmatrix} \begin{bmatrix} r_1 \\ r_2^* \end{bmatrix} \quad (3.5)$$

Using the properties of orthogonality of the matrix of code space-time worked out by Alamouti, the expressions of the variables of decision are a function only of one symbol of information. Thus, one recovers the values of the symbols transmitted except for a coefficient.

So by using STBC, we have designed and simulated MIMO encoder and decoder for 2x1, 2x2, 4x1 and 4x2 with BPSK and QPSK modulation. Comparison of MIMO OFDM system with respect to BER plot is shown in the simulation result.

IV. SIMULATION RESULTS

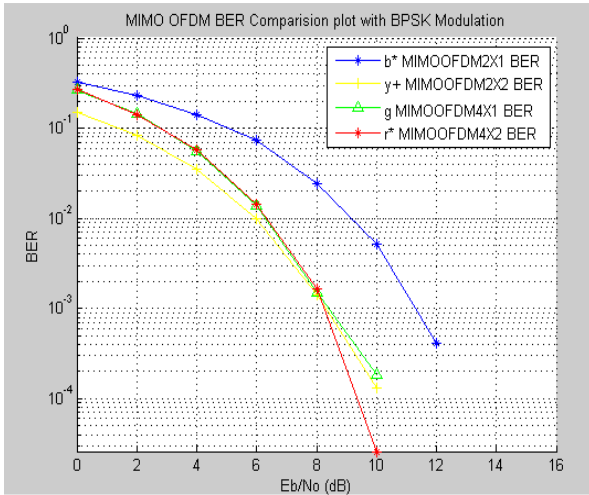

Fig 4.1: MIMO OFDM BER comparison plot with BPSK modulation

V. CONCLUSION

With the simulation results we can conclude that, MIMO 4x2 with BPSK modulation gives better performance than MIMO 4x2 with QPSK modulation, since MIMO 4x2 antenna configurations

have more channels than MIMO 2x2 antenna configurations.

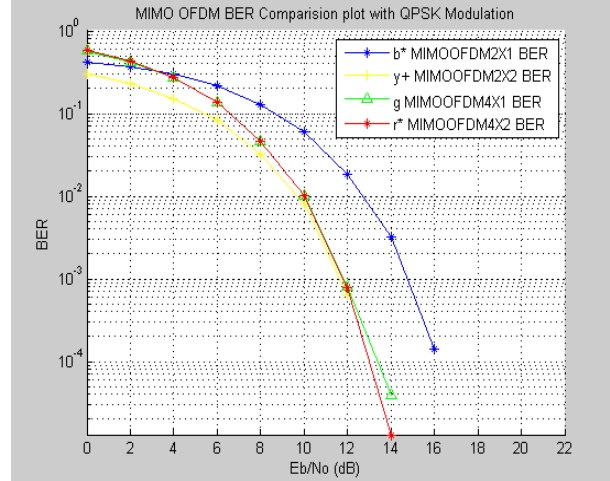

Fig 4.2: MIMO OFDM BER comparison plot with QPSK modulation

Hence reliability is directly proportional to the number of channels between STBC encoder and decoder.

REFERENCES

[1] R. S. Blum, Y. G. Li, J. H. Winters and Q. Yan, "Improved Space-Time-Coding for MIMO-OFDM Wireless Communications", *IEEE Transactions on Communications*, vol. 49, no. 11, pp. 1871-1878, 2001.

[2] Stuber, G.L, Barry, J.R, McLaughlin, S.W, Ye Li, Ingram, M.A, Pratt, T.G. "Broadband MIMO-OFDM wireless communications" *Proceedings of the IEEE* Vol 92, pp 271 -294, Issue 2, February 2004

[3] H. Bölcskei, A.J. Paulraj, "Space-frequency coded broadband OFDM systems," *Proc. IEEE WCNC*, Sept. 2000, vol.1, pp. 1-6.

[4 Part 11: Wireless LAN Medium Access Control (MAC) and Physical Layer (PHY) Specifications: High-Speed Physical Layer in the 5 GHz Band, *IEEE Standard* 802.11a-1999.

[5] T. Kaiser, A. Wilzeck, M. Berentsen, and M. Rupp, Prototyping for MIMO systems- an overview," in *Proceedings of 12th European Signal Processing Conference (EUSIPCO '04)*, pp. 681-688, Vienna, Austria, September 2004.

[6] S. Alamouti, "A simple transmit diversity technique for wireless communications," *IEEE J. Select. Areas Commun.*, vol. 16, pp. 1451-1458, Oct. 1998.

[7] V. Tarokh, H. Jafarkhani, and A. R. Calderbank, "Space-time block codes from orthogonal designs," *IEEE Trans. Inform. Theory*, vol. 45, pp. 1456-1467, July 1999.