



## Trend towards Energy Efficient UWSN Protocols

*Shivani Sachdeva\**, *Vishali Bansal\** and *Gurbinder Singh Brar\**

*\*Department of Computer Science and Engineering,  
AIET, Faridkot, (PB), INDIA*

*(Corresponding author: Shivani Sachdeva)*

*(Received 04 October, 2015 Accepted 04 November, 2015)*

*(Published by Research Trend, Website: www.researchtrend.net)*

**ABSTRACT:** In account to instability of underwater environment, the reliable data transfers is more sensitive issue in Underwater Wireless Sensor Networks (UWSNs) as compare to land based sensor network. Underwater networks are mostly designed by acoustic sensor nodes and surface sinks that are connected to any onshore control center. UWSNs have pulled in a quickly developing interest from researchers amid the last few years. In this paper, a brief survey of various protocols of UWSNs has been discussed. Because of the points of interest of simple deployment, self-management, and no necessity for infrastructure, UWSNs can be connected to an extensive variety of aspects, for example naval surveillance, earthquake and tsunami forewarning, atmosphere and sea observation, and water pollution tracking. UWSNs have different characteristics for example high propagation delay, restricted data transmission, and high error rate since acoustic signals are utilized for communications, instead of radio signals. The overall objective of this paper is to find the characteristics of various UWSNs protocols. This paper ends up with suitable research gaps i.e. various challenges of UWSNs which are required to handle in future research on UWSNs.

**Keywords:** UWSNS, Propagation Delay, Sink, Acoustic.

### I. INTRODUCTION

WSN is different from other popular wireless networks like cellular networks; wireless LAN and Bluetooth in many ways. WSN are planned for variety of monitoring applications. In these networks large number of nodes sometimes takes measurements of environmental data and transmits them to a central data sink. The basic step of working of WSN: Sensing > Computation > Communication-> Data aggregation at sink node->. various applications. With the development in wireless technology and embedded device technology, the capacity of the sensors is quite better while their cost is lesser. A wireless sensor network consists of hundreds to thousands of sensor nodes with much shorter distance between neighboring nodes and low application data rate.

WSN has more opportunities to be deployed in actual environments. In current years WSN becomes promising field in wide range of applications like health monitoring applications, environmental surveillance, forecasting system, battlefield observation, robotic exploration, monitoring of human physiological data etc.

The sensors can be deployed at various places with different usages and each have unlike capability to sense different attributes like temperature, moisture, pressure humidity etc. But these sensors have restricted power sources and also it is not cost effective to renew the

batteries. The batteries are typically irreplaceable. Therefore, there life span will depends on respective batteries of sensors. So the life time of wireless sensor network can be extended by using efficient energy Balancing methods.

Earth is mostly covered by water. This is mainly unexplored area and recently humans are showing awareness towards exploring it Underwater Acoustic Sensor Networks (UWASN) consist of a variable number of sensors that are deployed to perform the monitoring tasks over a given area. Numerous disasters that took place in recent past made humans to greatly monitor the oceanic environments for scientific, environmental, military needs etc., in order to perform these monitoring task industries are showing attention towards deploying sensor nodes under water.

TWSNs operate in the surroundings dominated by RF communication. Yet, RF communication is not an most favorable communication channel for underwater applications because of the extremely limited RF wave's transmission underwater. Conductive sea water only at extra low frequencies (30 ; 300 Hz), which require huge antennae and high communication power. Thus, links in underwater networks are based on acoustic wireless communications.

Acoustic communications are the typical physical layer technology in underwater networks.

The acoustic communication, while more trustworthy and robust, is bandwidth limited. Underwater acoustic rates are between 5kb/s and 20kb/s, which is extremely slow compared to over air RF rate(in Gb/s).

In internal architecture the CPU on board manager, sensor interface circuitry, acoustic modem, memory, power supply and sensor are main component. It consist of the main controller which is interface with sensor through a sensor interface circuitry. The CPU or controller receive the data from the sensor and stored it in the memory, process it and send to the another sensor through the acoustic modem. Sometimes all the sensor component are protected by the Bottom-mounted device frames that are design to permit azimuthally omni directional communications, and protect the sensor and modem from potential impact of trawling gear

The internal architecture of underwater sensor is shown below:

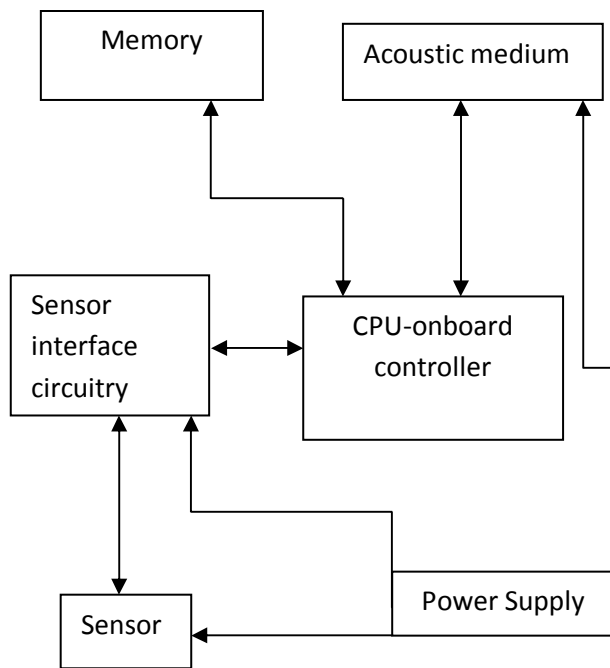

Fig. 1. Internal Architecture.

Acoustic waves present different signal attenuations depending on distance and frequency. In addition, the signal spreading is proportional to the distance due to the extension of the wave-fronts and can be in a cylindrical or spherical form. Another problem faced by underwater communication comes with the signal

transmission, which is 1,500 m/s and five orders of scale lower than in RF. In radio-frequency networks this delay is negligible but in underwater acoustic networks it is significant to be considered.

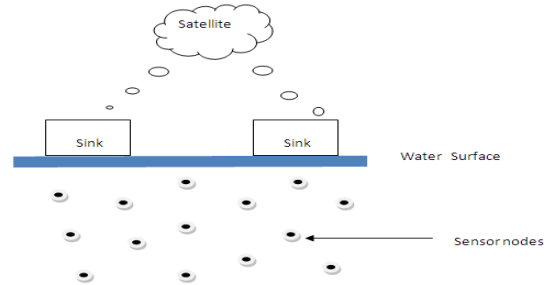

Fig. 2. Underwater Wireless Sensor Network.

## II. ISSUES SOLVED TILL DATE

Some authors have discussed energy efficiency and analysis (Ovaliadis and N.S.a.V.K, 2010; Domingo and Prior, 2008), deployment (Pompili *et al.*, 2009), potential applications (Heidemann *et al.*, 2006; Jiejun *et al.*, 2005), network coding schemes (Lucani *et al.*, 2007), and multiple access techniques (Casari *et al.*, 2007) but here in this review paper the routing protocols issues of UWSN are classified and discussed thoroughly.

### A. Mobility

**Location Aware Routing.** VBF is often a location-based direction-finding method with regard to UWSNs planned by simply Xie *et al.* [1]. Within this standard protocol, state details of the sensor nodes are not essential considering that only limited nodes are involved throughout packet forwarding. After a new supply is obtained, the node computes its comparable placement depending on forwarder[2]. All the supply forwarders inside sensor circle style a new "routing pipe", the sensor nodes on this conduit meet the criteria with regard to supply forwarding, and those that are not really nearby the direction-finding vector usually do not forward.

VBF possesses quite a few necessary negatives[3]. Primary, using a exclusive direction-finding water line from resource to destination can impact the actual direction-finding productivity along with different node densities. Second, VBF is incredibly delicate in regards to the direction-finding water line radius limit, and also this limit can impact the actual direction-finding effectiveness considerably; like attribute will not be appealing in the real protocol developments.

Additionally, several nodes across the direction-finding water line are employed time and again so that you can forwards your data packets from solutions towards sink , that may wear out their battery. W. Bo.et.al[4] proposed ES-VBF: An Energy Saving Routing Protocol Throughout SBR-DLP[5] the particular sensor nodes will not be forced to take neighbor topology. Every node is actually believed to understand its own location, along with the location node's pre-planned motions. As found within Figure 3, any node S has a data packet which should be sent to destination D. To start with, it's going to try to look for its next hop through broadcasting Chk\_Ngb packet, which includes I gets Chk\_Ngb may verify whether it's closer towards destination node N than distance involving in S and D. The particular nodes in which fulfill condition may answer node S through sending any Chk\_Ngb\_Reply packet

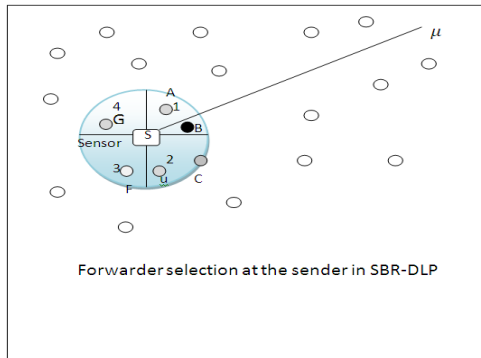

Fig. 3. The SBR-DLP routing protocol.

The SBR-DLP allows the sender decide its next hop using information received from the candidate nodes. Therefore proposed SBR every single applicant node decide whether it will relay the packet; this reduces problem of having numerous nodes acting as relay nodes, that is stumbled upon throughout each VBF as well as HH-VBF[1][2].

**Depth Routing.** DBR(depth based protocol) standard protocol [6] does flooding along with the usage of depth information of the sensor nodes regarding direction-finding. The depth of a sensor node is acquired utilizing a depth sensor attached to node. The particular offered standard protocol relaxes the necessity of localization, which is high-priced in UWSN, with the use of depth information of the sensor nodes. Within DBR, each and every node gives its depth information to data packet. A node after having the data packet transports this packet if the receiving node's depth is smaller compared to the transmitter's depth. S. Ahmed *et.al.* [7] proposed Adaptive mobility of Courier nodes in Threshold-optimized Depth-based routing (AMCTD) to Achieve

longer network lifetime Mohsin Raza Jafri *et.al.* [8] proposed Delay-Sensitive Depth-Based Routing (DSDBR), Delay-Sensitive Energy Efficient Depth-Based Routing (DSEEDBR) and Delay-Sensitive Adaptive Mobility of Courier nodes in Threshold-optimized Depth-based routing (DSAMCTD) protocols to have Efficient data forwarding, minimal relative transmissions in low-depth region and better forwarder selection. A.Umar *et al.* [9] proposed An extension of IAMCTD (Improved Adaptive Mobility of Courier nodes in Threshold-optimized DBR protocol for UWSNs) which avoids control overhead that was present in IAMCTD, increases throughput, stability period is improved and node density per round remains comparatively high improving the overall network reliability

Within [10], this flooding primarily based tactic is employed along with the usage of one of a kind IDs of the sensor nodes. The unique ID. (called a hop ID) illustrates the distance (in terms of hop count) from a sink node on the sensor node

**Tree Structure Routing.** In [11] cluster based method, DUCS(distributed underwater clustering scheme) is proposed. HydroCast (hydraulic force dependent anycast routing) [12] method utilizes interesting depth details (pressure level) of the sensor nodes combined with clustering of the nodes. In the group sourcing method, it can be taken into account the picked groups include absolutely no undetectable terminal nodes.

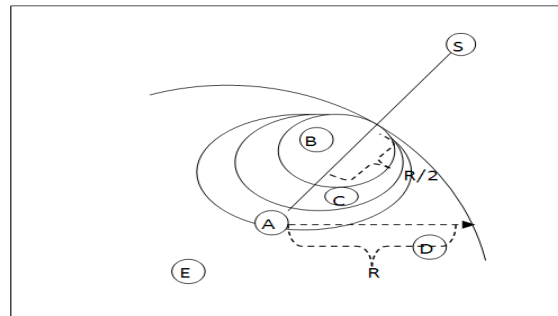
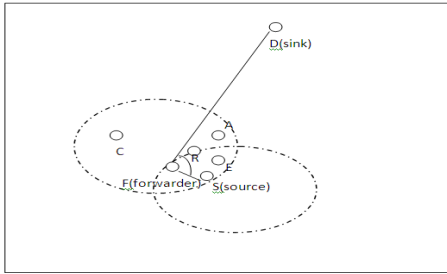

Fig. 4. Adaptive scheme.

#### B. Reliable Routing

**Location Aware Routing.** DFR(directional flooding routing protocol) effectively making it possible for no less than one node to help attend forwarding a packet. Within DFR[13], a packet transmission relies on a scoped flooding, i.e. a flooding area is created to help reduce this flooding inside complete network. That area is determined using an angle involving will be the node which receives a packet, S and D i.e destination.



**Fig. 5.** An example of a packet transmission in DFR.

The desire to triumph over two complications experienced because of the VBF, i.e. small files delivery ratio throughout sparse networks, as well as tenderness on the routing pipe's radius, the particular HH-VBF (hop-by-hop VBF) proposed by Nicolaou *et al.* [2]. Due to hop-by-hop nature [14], HH-VBF is not able to give a suggestions process to help identify and prevent voids in the network as well as energy performance remains low in comparison with VBF.

### C. Energy Efficiency

**Location Aware Routing.** The suggested protocol reliable and energy balanced algorithm routing (REBAR) [16] location based direction-finding protocol which focuses on several significant difficulties to be able to treat with UWSNs: energy consumption, delivery ratio and also managing void problem. The direction-finding strategy of REBAR [17] consists that many node within the network incorporates a confined radius that is worried about it is range to sink. The source computes a directional vector  $v$  from itself to destination. The Euclidian distance from source to sink  $d$  the packet. The packet will be designated that has a exclusive identifier (ID), that is composed of the original source IDENTIFICATION and a sequence number. The packet will be broadcasted within the network. Every single receiver keeps a barrier to be able to report the particular IDENTIFICATION of recently gotten packets. Duplicates is usually taken care by the history and will be discarded. Figure 6 describes the illustration of the direction-finding strategy of REBAR

**Multipath Routing.** MCCP (minimum cost clustering protocol) [18] is really a group dependent method in which groups tend to be formed according to a price metric. A clustering criteria [19][20] using the geographical location of the sensor nodes with 3-Dimensional topology multilevel architecture known as LCAD.

On this process, the whole multilevel can be broken down in to 3- Dimensional topology [21] Numerous multi-hop direction finding methodologies are already recommended for under the sea sensor networks, however many of them encounter the challenge involving multi-hop direction finding where nodes across the sink drain additional energy and they are suspected to be pass away early. To resolve this matter as well as make equivalent energy use throughout, Ayaz *et al.* (2010) [22] introduced a Temporary Cluster Based Routing (TCBR) algorithm.

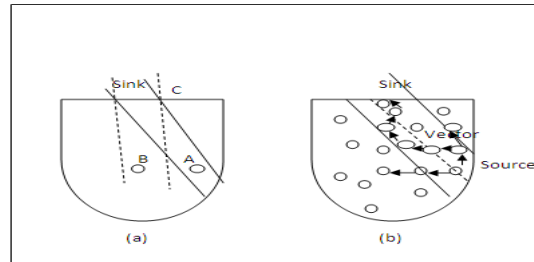

**Fig. 6.** The routing process of REBAR.

Underwater sensor nodes are battery power-driven and these batteries are not able to be replaced easily so power efficiency is a important issue for these environments. Moreover, really long delays for acoustic interactions could lead to the disintegrate of habitual terrestrial direction-finding protocols because of limited response waiting time. To handle these issues, Chun-Hao and Kuo-Feng (2008) [23] proposed an energy-efficient routing protocol called EUROP, where they tried to lessen huge amount of energy utilization by reducing broadcast hello messages.

### D. End to end delay

**Single Path Routing.** ICRP (information carrying based routing protocol) [24] is non-localized and reactive process. In the proposed scheme, a mobile source along with a mobile destination node are considered. This reactive system is required to the extent in which simply no explicit RREQ packet can be fed. Alternatively, a path is made by broadcasting data packet (which additionally works like a RREQ packet). Originally, the source node broadcasts data packet as well as the intermediate nodes rebroadcast the obtained packet. About receiving packet, destination node posts a reply. This destination node's reply follows the way, documented throughout the transmission of the files packet. So, a way through the source to destination can be came from without having taking advantage of the explicit RREQ packet.

**Multipath Routing.** The focused beam routing (FBR) suppose that each node knows only its own local proposed protocol, variable transmission power levels are used in the forwarding of data packet, and this transmission power have a range from P corresponding transmission radius d the destination [25].

The selection of the next forwarder is done as follow:

Firstly, source node multicasts an RTS in their neighborhood with the lower power level P second step we have three cases:

**1. One reply with CTS packet:** If only one node survive in the transmission radius, it will reply by a CTS and will be the forwarder

**2. Multiple replies with CTS packet:** node (the closest to the destination) for the transmission of packet.

**3. Any CTS packet are replayed:** increased to the higher level until receiving a CTS reply. If the maximum level is reached without receiving a CTS packet thus the cone of angle must be shifting in the left or the right of the first cone.

**Table 1: Performance characteristics of the routing protocols for UWSN.**

Protocol	Routing approach	Delivery ratio	Energy efficiency	End-to-end delay	Localization needed
HH-VBF	Flooding (vector based)	High	Medium	Medium	Yes
FBR	Flooding (vector based)	Medium	Medium	High	Yes
DBR	Flooding (depth based)	High	Medium	Medium	Partially
H <sup>2</sup> -DAB	Flooding (addressing based)	Medium	High	High	No
DFR	Flooding (vector based)	Medium	Medium	Medium	Yes
SBR-DLP	Flooding (vector based)	Medium	High	High	Yes
Dario Pompili <i>et al.</i> scheme	Path based	High	Medium	Low	Yes
MPT	Path based	Medium	Medium	High	No
MCCP	Clustering (distributed)		High	High	Yes
DUCS	Clustering (distributed)	Medium	High	High	No
HydroCast	Clustering (distributed)	High	High	High	No
Adaptive	Priority based	Flexible	Flexible	Flexible	Yes
ICRP	Path based	Medium	Low	High	No

### III. LITERATURE SURVEY

Protocol	Hop-by-hop	Clustered	multi sink	control packets	Constraints	controlled	Features	Year of pub.
VBF (Xie <i>et al.</i> , 2006b)	Y	N	N	N	Geo. location is available	Whole network	Considered as first geographic routing approach for UWSN	2006
HH-VBF (Nicolau <i>et al.</i> , 2007)	Y	N	N	N	Geo. location is available	Whole network	Enhanced version of (Xie <i>et al.</i> , 2006a), robustness improved by introducing hop-by-hop approach instead of end-to-end	2007

Protocol	Hop-by-hop	Clustered	multi sink	control packets	Constraints	controlled	Features	Year of pub.
FBR (Jornet <i>et al.</i> , 2008)	Y	N	Y	Y	Geo. location is available	Own and sink location	A cross layer location-based approach, coupling the routing, MAC and phy. layers.	2008
DFR (Daeyoung and Dongkyun. 2008)	Y	N	N	N	Geo. location is available	Own, 1-hop neighbors and sink info.	A controlled packet flooding technique, which depends on the link quality, while it assumed that, all nodes can measure it	2008
REBAR (Jinming <i>et al.</i> , 2008)	Y	N	N	N	Geo. location is available	Own and sink location info.	Similar with (Jornet <i>et al.</i> , 2008) but use adaptive scheme by defining propagation range. Water movements are viewed positively	2008
ICRP (Wei <i>et al.</i> , 2007)	N	N	N	N	N/A	Source to sink information	Control packets of route establishment are carried out by the data packets	2007
DUCS (Domingo and Prior. 2007)	Y	Y	N	Y	N/A	Own cluster info. (1-hop)	A self-organizing algorithm for delay-tolerant applications, which assumes that sensor nodes always have data to send	2007
Packet Cloning (Peng <i>et al.</i> , 2007)	Y	N	Y	N	N/A	amount and sequence of clones	Unlike controlled broadcast, discernible clones of a data packet are forwarded according to network conditions	2007
SBR-DLP (Chirdchoo <i>et al.</i> , 2009)	Y	N	N	Y	Geo. location is available	Own location and sink movement	Similar with (Jinming <i>et al.</i> , 2008), but does not assumes that destination is fixed plus it consider entire communication circle instead of single transmitting cone	2009
Multipath Virtual Sink (Seah and Tan 2006)	Y	Y	Y	Y	Network with special setup	Own cluster information	Advantage of multipath routing without creating any contention near the sink	2006
DDD (Magistretti <i>et al.</i> , 2007)	N	N/A	N/A	Y	Network with special setup	About dolphin node presence	A sleep and wake-up scheme, which requires only one-hop transmission	2007
DBR (Yan <i>et al.</i> , 2008)	Y	N	Y	N	Nodes with Special H/W	No network information maintained	Considered 1st depth based routing. After receiving data packet, nodes with lower depth will accept and remaining discards	2008
H2-DAB (Ayaz and Abdullah. 2009)	Y	N	N	Y	N/A	1-hop neighbor's	Short dynamic addresses called Hop-IDs are used for routing, assigned to every node according to their depth positions	2009

Protocol	Hop-by-hop	Clustered	multi sink	control packets	Constraints	controlled	Features	Year of pub.
HydroCast (Uichin <i>et al.</i> , 2010)	Y	Y	Y	N	Nodes with Special H/W	2-hop neighbor's	Similar with (Yan <i>et al.</i> , 2008). Any cast pressure based routing, a subset of forwarder nodes are selected to maximize greedy progress	2010
EUROP (Chun-Hao and Kuo-Feng, 2008)	Y	N	N	Y	Network with special setup	1-hop neighbor's	Nodes are deployed in layers. Water pressure is used for deep to shallow depth based routing	2008
MCCP (Pu <i>et al.</i> , 2007)	Y	Y	Y	Y	N/A	2-hop neighbor's	2-hop cluster formation algorithm, but does not support multi-hop communication	2007
TCBR (Ayaz <i>et al.</i> , 2010)	Y	Y	Y	Y	Network with special setup	3-hop neighbor's	Temporary clusters are formed to balance energy consumption in whole network	2010
Resilient Routing (Dario Pompili and Ian 2006)	N	N	N	N	Nodes with Special H/W	Discovered paths to destination	A 2-phase resilient routing. First, primary and backup paths are configured, and then these are repaired if node failure occurs	2006
LCAD (Anupama <i>et al.</i> , 2008)	N	N	N	Y	Network with special setup	Source to sink information	A DSR modification. Location and link quality awareness is included. Preferred only for small networks	2006
Adaptive Routing (Zheng <i>et al.</i> , 2008)	Y	N	N	Y	N/A	Own and 1 hop neighbors info	Both, the packet and network characteristics are considered before deciding about the packet forwarding	2008

Table 4: Comparison of DBR protocols.

Protocol	Stability	Energy Consumption	Throughput	End-end delay	Transmission loss	Year
EEDBR (Wahid. <i>et al.</i> 2011)	Poor	Low	Low	More	Less	2011
AMCTD(S. Ahmed <i>et.al</i> 2013)	Average	Low	Low	More	Less	2013
DSDBR, DSEEDBR, DSAMCTD (Mohsin Raza Jafri <i>et.al</i> 2014)	High	Low	Low	Less	Less	2014
An extension of IAMCTD(A.Umar <i>et al.</i> 2014)	Highest	High	High	Stabilized	More	2014

### Gaps With in Literature

- (i) Use of the data fusion to enhance the routing has been neglected.
- (ii) The use of lossless data compressing sensing to improve the results has also been ignored.
- (iii) To achieve high throughput in most of the existing techniques results increases transmission loss.

### IV. CONCLUSION AND FUTURE WORK

This paper has shown a survey of advanced routing methods throughout underwater sensor system. Direction-finding for UWSN is usually an crucial problem, and that is bringing important awareness from the experts. The structure of any direction finding process depends on objectives and demands from the application, in addition to appropriateness, which often be based upon availability of multilevel resources. This includes the initial characteristics of UWSN and outlined advantages and overall performance problems of each scheme. Lastly, contrast of strategies in accordance with their particular attributes and benefits has been done. This paper has reviewed an extension of IAMCTD that has been targeted on enhancing network reliability and throughput for critical-range based applications. In near future the improvement will be done in Extension of IAMCTD using data fusion and the lossless data compressing sensing in order to reduce the amount of data which are going to be transmitted. The reduction in packet size will improve the QoS parameters of UWSNs thus will enhance the energy efficiency further.

### REFERENCES

[1]. Xie, Peng, Jun-Hong Cui, and Li Lao. "VBF: vector-based forwarding protocol for underwater sensor networks." NETWORKING 2006. Networking Technologies, Services, and Protocols; Performance of Computer and Communication Networks; Mobile and Wireless Communications Systems. Springer Berlin Heidelberg, 2006. 1216-1221.

[2]. Nicolaou, N., See, A., Xie, P., Cui, J. H. and Maggiorini, D. (2007) "Improving the Robustness of

[3]. Location-Based Routing for Underwater Sensor Networks," *IEEE Oceans 2007 Conf. - Europe*, pp.1-6.

[4]. Ibrahim, Dina M., *et al.* "Enhancing the Vector-Based Forwarding Routing Protocol for Underwater Wireless Sensor Networks: A Clustering Approach." ICWMC 2014, The Tenth International Conference on Wireless and Mobile Communications. 2014.

[5]. W. Bo, L. Yong-mei, and J. Zhigang, "ES-VBF: An Energy Saving Routing Protocol," Proc. of the 2012 International Conference on Information Technology and Software Engineering, 2012, pp. 87-97

[6]. Chirdchoo, N.; Wee-Seng Soh; Kee Chaing Chua, "Sector-Based Routing with Destination Location Prediction for Underwater Mobile Networks", *IEEE international*

conference on Advanced Information Networking and Applications WAINA'09, pp. 1148- 1153, 2009.

[7]. Hai Yan, Zhijie Shi, Jun-Hong Cui, "DBR: Depthbased Routing for Underwater Sensor Networks", Springerlink NETWORKING, pp.16-1221, 2008.

[8]. Jafri, Mohsin Raza, S. Ahmed, Nadeem Javaid, Z. Ahmad, and R. J. Qureshi. "Amctd: Adaptive mobility of courier nodes in threshold-optimized dbr protocol for underwater wireless sensor networks." In *Broadband and Wireless Computing, Communication and Applications (BWCCA)*, 2013 Eighth International Conference on, pp. 93-99. IEEE, 2013.

[9]. Jafri, Mohsin Raza, Muhammad Moid Sandhu, Kamran Latif, Zahoor Ali Khan, Ansar Ul Haque Yasar, and Nadeem Javaid. "Towards delay-sensitive routing in underwater wireless sensor networks." *Procedia Computer Science* **37** (2014): 228-235.

[10]. Umar, A., *et al.* "On Enhancing Network Reliability and Throughput for Critical-range based Applications in UWSNs." *Procedia Computer Science* **34** (2014): 196-203.

[11]. Ayaz M, Azween Abdullah, "Hop-by-Hop op Dynamic Addressing Based (H2-DAB) Routing Protocol for Underwater Wireless Sensor Networks", *IEEE international conference on Information and Multimedia Technology ICIMT '09*, pp. 436-441,2009.

[12]. Domingo M.C, Prior, R. , "Design and Analysis of a GPS-free Routing Protocol for Underwater Wireless Sensor Networks in Deep Water", *International Conference on Sensor Technologies*

[13]. Uichin Lee, Paul Wang, Youngtae Noh, Luiz F.M.Vieira, Mario Gerla, Jun-Hong Cui, " Pressure Routing for Underwater Sensor Networks", *IEEE INFOCOM*, pp. 1-9, 2010.

[14]. Daeyoung Hwang, Dongkyun Kim, "DFR: Directional flooding-based routing protocol for underwater sensor networks" *IEEE OCEANS 2008*, pp. 1-7, 2008.

[16]. Aarti, Tomar, Sanjiv Kumar. "A reliable and cost effective next hop selection for aggregative path generation in UWSN." In *Wireless and Optical Communications Networks (WOCN)*, 2013 Tenth International Conference on, pp. 1-5. IEEE, 2013.

[17]. D Pompili, T Melodia, IF Akyildiz, "A resilient routing algorithm for long-term applications in underwater sensor networks", *MedHoc Net*, pp. 22-9, 2006.

[18]. Wang, Y., Gao, J. and Mitchell, J. (2006) "Boundary recognition in sensor networks by topological methods," Proc. of ACM MobiCom, pp. 122-133.

[19]. Fekete, S., Kroeller, A., Pfisterer, D., Fischer, S. and Buschmann, C. (2004) "Neighborhood-based topology recognition in sensor networks," *Proceeding of First International Workshop on Algorithmic Aspects of Wireless Sensor Networks (ALGOSENSOR)*, pp. 123-136.

[20]. Pu Wang, Cheng Li, Jun Zheng, "Distributed Minimum-Cost Clustering Protocol for Under Water Sensor Networks (UWSN)", *IEEE International Conference on Communications ICC'07*, pp. 3510- 3515, 2007.

[21]. Younes, O. and Fahmy, S. (2004) "HEED: A hybrid, energy-efficient, distributed clustering approach for ad hoc sensor networks", *IEEE Transactions on Mobile Computing*, vol.3, no.4, pp.366-379.



- [22]. Lindsey, S. and Raghavendra, C.S. (2002) "PEGASIS: Power-Efficient Gathering in Sensor Information Systems", *IEEE Transaction on Parallel and Distributed Systems*, vol.13, no.9, pp.924-935
- [23]. Anupama, KR., Sasidharan, A. and Vadlamani, S., (2008) "A location-based clustering algorithm for data gathering in 3D underwater wireless sensor networks" *In Proceedings of the International Symposium on Telecommunications, IST*, vol. No. (343-348).
- [24]. Ayaz, Muhammad, Azween Abdullah, and Low Tang Jung. "Temporary cluster based routing for Underwater Wireless Sensor Networks." *In Information Technology (ITSim), 2010 International Symposium in*, vol. 2, pp. 1009-1014. IEEE, 2010.
- [25]. Chun-Hao Y, Kuo-Feng S. An energy-efficient routing protocol in underwater sensor networks. In: *Proceedings of the 3rd international conference on sensing technology*, ICST; 2008.
- [26]. Wei Liang, Haibin Yu, Lin Liu, Bangxiang Li, Chang Che, "Information-Carrying based Routing Protocol for Underwater Acoustic Sensor Network", *International Conference on Mechatronics and Automation ICMA 2007*, pp.729-734, 2007
- [27]. Jornet, J. M., Stojanovic, M. and Zorzi, M. (2008) "Focused beam routing protocol for underwater acoustic networks," in Proceeding of the third ACM International Workshop on Under Water Networks WUWNet, San Francisco, California, USA.
- [28]. Zhong Zhou, Jun-Hong Cui, "Energy Efficient Multi-Path Communication for Time-Critical Applications in Under water Sensor Networks", *ACM MobiHoc'08*, pp. 221-230, 2008.
- [29]. Zhen Guo, Gioele Colombi, Bing Wang, Jun-Hong Cui, Dario Maggiorini, Gian Paolo Rossi, " Adaptive Routing in Underwater Delay/Disruption Tolerant Sensor Networks", *Fifth Annual Conference on Wireless on Demand Network Systems WONS 2008*, pp. 31-39, 2008.
- [30]. Ian F. Akyildiz, Dario Pompili, Tommaso Melodia, State of the Art in Protocol Research for Underwater Acoustic Sensor Networks, WUWNet06, September 25, 2006, Los Angeles, California, USA, ACM 1-59593-484-7/06/0009...\$5.00.