



Comparative Study of Conventional Absorber using Porous Media in CSP with and without Nano Fluid Flow Using CFD Analysis

Vivek Tiwari¹ and Prashant Sharma²

¹Research Scholar, Department of Mechanical Engineering, RGPV, Bhopal (Madhya Pradesh), India

²Associate professor, Department of Mechanical Engineering, RGPV, Bhopal (Madhya Pradesh), India

(Corresponding author: Vivek Tiwari)

(Received 15 March, 2018 Accepted 30 May, 2018)

(Published by Research Trend, Website: www.researchtrend.net)

ABSTRACT: Performance of solar collectors depends upon various factors like collector & receiver material, solar intensity, nature of working fluid etc. Above all, nature & the properties of the working fluid which flows through the collectors, greatly effects its performance. Here, an attempt has been made to improve the performance of a parabolic solar collector by using nanofluids instead of conventional fluid like water as working fluid with porous media. The present investigation mainly focuses on the nanofluid based concentrating parabolic solar collector (NBCPSC). Nanofluids are the suspensions of metallic or non-metallic nanoparticles like aluminum, aluminum oxide, copper oxide etc. in base fluids like water, ethylene glycol, oil etc. The performance of a parabolic solar collector is investigated experimentally by studying the effect of alumina (Al_2O_3) nanoparticles in water, as working fluids. Three mass flow rates (1, 2 & 5) l/min and particles volume concentrations of 0.04% have been examined. Comparison of water based alumina nanofluid is done with air and water and it is observed that by using Al_2O_3 nanofluid as a working fluid the value for maximum instantaneous & thermal efficiency has been improved. Therefore, from the results it can be concluded that the performance of solar collector with porous media is remarkably enhanced by using nanofluids as working fluid in the solar collector.

Keywords: Parabolic Trough Solar Collector, Porous Media, Nano Fluid, Al_2O_3 . H_2O .

1. INTRODUCTION

In present's world the prosperity of nation is measured by the energy consumption of that nation, the GDP of country is directly linked with energy consumption. Therefore demand for energy resources is increasing day by day. There are various types of energy resources, but mainly they are divided in to two forms, these are renewable energy resources (solar, air, wind) and nonrenewable energy resources (coal, petroleum). The industrial growth is accelerated by nonrenewable energy resources, but there stock is limited in nature. The rapid depletion of fossil fuel resources has necessitated an urgent search for alternative energy sources to meet the energy demands for the immediate future and for generations to come. Of many alternatives, solar energy stands out as the brightest long range promise towards meeting the continually increasing demand for energy. The major drawback with this resource is its low intensity, intermittent nature and non-availability during night. Even in the hottest region on earth, the solar radiation flux available

rarely exceeds 1 kW/m^2 . In spite of these limitations, solar energy appears to be the most promising of all the renewable energy resources. Solar energy is contemplated to have a wide range of applications including water heating, air heating, air-conditioning of buildings, solar refrigeration, photo-voltaic cells, green houses, photo-chemical, power generation, solar furnaces and photo-biological conversions to list a few. Out of these, the utilization of solar energy for power generation and heating/cooling of buildings is the subject of active research these days.

Solar thermal systems play an important role in providing non-polluting energy for domestic and industrial applications. Concentrating solar technologies like compound parabolic collector, parabolic dish and parabolic trough are used to supply industrial process heat, off-grid electricity and bulk electrical power since they can operate at high temperatures. In a parabolic trough solar collector, or PTSC, the reflective profile focuses sunlight on a linear heat collecting element(HCE) through which a heat transfer fluid is pumped.

The solar energy is capture by the fluid which can then be used for various applications. Key components of a PTSC include the collector structure, the receiver or HCE, the drive system and the fluid circulation system, which delivers thermal energy to its point of use.

II. PARABOLIC TROUGH TECHNOLOGY

Line concentration uses a trough-like mirror to concentrate the incoming solar radiation onto an absorber tube by one-axis tracking system. The most important line concentrating technologies are the parabolic trough collectors (PTC) and linear Fresnel reflector systems (LF). Depending to their design, PTC and LF are able to concentrate the solar radiation flux 30–80 times in order to heat a thermal fluid up to 400°C. The absorber tube may be made by steel or copper and coated with a heat resistant black paint. Parabolic trough is today considered a fully mature technology where technological and financial risks are expected to be low. PTC is a focal line solar concentrating technology where thermal fluid passes through a receiver tube to absorb the concentrated solar energy reflected by parabolic trough-shaped mirrors. PTC applications can be divided in two main groups depending on the temperature range. The first and most important application is the concentrated solar power (CSP) plants for electric generation where temperature is from 300 to 400 °C. The other group of applications requires temperature between 100 and 250°C. The main applications of this range are the industrial process heat (IPH), low-temperature heat demand, space heating and swimming pool and heat driven refrigeration and cooling.

III. AIR HEATERS WITH POROUS ABSORBERS [6]

In this type of air heaters, incoming radiations are absorbed as these travel through a porous bed consisting of packing elements of different shapes, sizes and porosities. There are various types of packing elements which are being used for solar air heaters like glass beads, crushed glass, iron turnings, slit, metal sphere and expanded aluminum foils and wire screens. Porous absorbers offer several advantages which include high heat transfer area to volume ratio, high heat transfer coefficient and absorption of energy ‘in depth’ resulting in reduced top layer temperature and thus less heat losses with higher efficiency.

IV. NANO FLUID

Nano fluids denote to a solid-liquid mixture or suspensions produced by dispersing tiny metallic or nonmetallic Solid Nano particles in liquids. Nano fluids are a new class of fluids engineered by dispersing nanometer sized materials (Nano-particles, Nano-fibers, Nano-tubes, Nano-wires and Nano-rods) in base fluids.

The size of nanoparticles (usually less than 100nm) in liquids mixture gives them the ability to interact with liquids at the molecular level and so conduct heat better than today’s heat transfer fluids depending on nano particles. Nano fluids can display enhanced heat transfer because of the combination of convection & conduction and also an additional energy transfer through gamma - particles dynamics and collisions. Metallic Nano fluids have been found to possess enhanced thermo physical properties such as thermal conductivity, thermal diffusivity, viscosity and convective heat transfer coefficients compared to those of base fluids like oil or water [2],[5].

V. METHODOLOGY

Modelling of Parabolic Trough Solar Collector

For designing the absorbing tube without porous medium, following steps is followed for geometry modelling in CATIA V5 workbench:

- Open CATIA V5 R20
- Select a plane & draw a circle of appropriate diameter
- Use pad Command to generate a cylinder of desired length
- Use Shell command to hollow the cylinder to convert it into a pipe
- Select a face on the end of the Receiver tube and draw a circle matching the diameter of inner circle
- Pad this sketch to match the absorber length
- Save the model in .stp format.

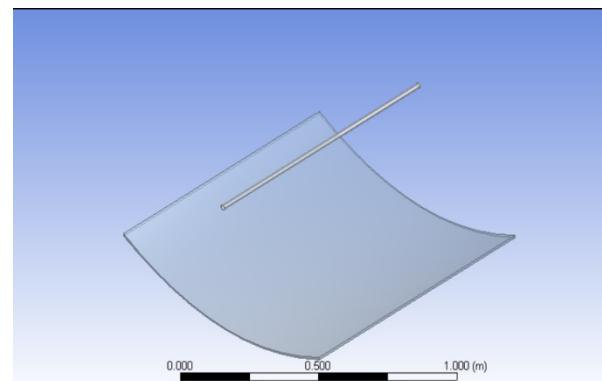

Fig. 3.3: 3. D model of absorber tube and solar collector With Porous Medium in CATIA V5

Table 1: Thermal properties of solar collector material.

Material	Density[k g m ⁻³]	Specific Heat [Jkg ⁻¹ K ⁻¹]	Thermal conductivity[Wm ⁻² K ⁻¹]
Copper	8978	381	387.6
Glass	2529.6	754.04	1.1717

Table 2: Thermal properties of Material used as Working Fluid [4].

Material	Density [kg m ⁻³]	Specific Heat [J kg ⁻¹ K ⁻¹]	Thermal conductivity [W m ⁻¹ K ⁻¹]	Viscosity [kg/m-s]
Water	1000	4187	0.667	0.415x10 ⁻⁶
Air	1.225	1006.43	0.0242	1.7894x10 ⁻⁵
Nano Fluid (Al ₂ O ₃)	1311.5	880	0.0454	0.04

Table 3: Properties of Porous Medium.

Material	Copper
Porosity	0.90
Permeability, K (m ²)	1.37 × 10 ⁻¹¹
Length, L _f (mm)	250
Diameter, D (mm)	16
Thermal conductivity (W/m.K)	399

Table 4: Dimension of Parabolic Solar Collector.

	Dimension
Receiver Pipe Length	1000 mm
Receiver Pipe Outer Diameter	20 mm
Receiver Pipe Inner Diameter	16 mm
Parabolic Solar Trough Length	1000 mm
Parabolic Solar Trough Breadth	1000 mm
Parabolic Solar Trough Thickness	2 mm

VI. MODELLING AND ANALYSIS

- The designed 3D model of the parabolic trough solar collector is imported in DESIGNMODULAR of ANSYS FLUENT. [fig. (a)]
- Next step of the simulation is to assign proper names to the geometry so named selection of various parts is done. [fig. (b)]
- Next the geometry is imported to MESHING MODULE of the FLUENT to generate mesh of the model. This is a process of breaking bigger geometry into number of elements and nodes. [fig. (c)](Ref. [1])

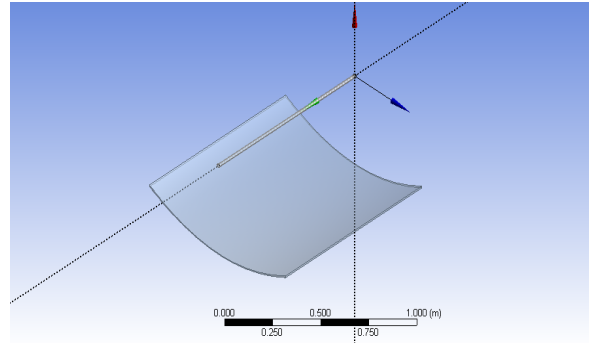

Fig. (a)

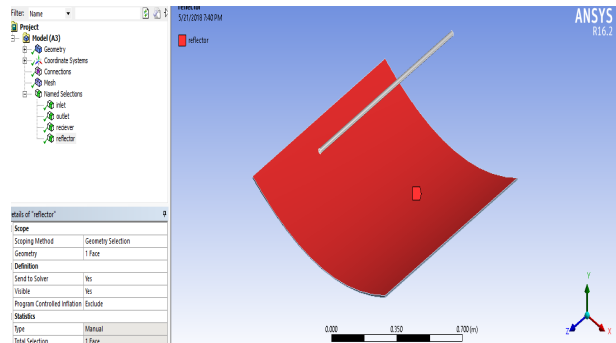

Fig. (b)

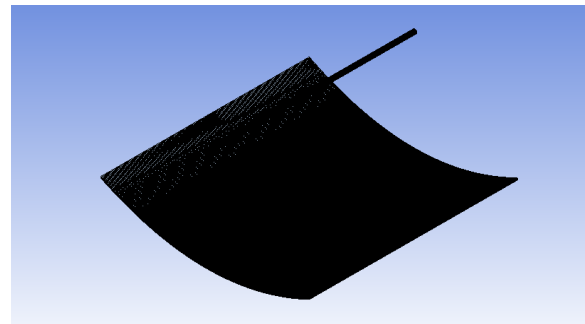

Fig. (c)

Table 5

Solver Settings	
Solver	Isolated
Formulation	Implicit
Time	Steady
Velocity Formulation	Absolute
Gradient option	Cell-based
Operating Conditions	
Operating Pressure	
Reference Pressure Location	
Gravity	Qualified
Gravitational Acceleration	Enabled
Energy Model	
Energy Equations	Qualified
Viscous Model	
Model	Enhanced (Thermal Effect)
Wall-treatment	Default
Model Constant	Default
Options	Buoyancy Effect
Solar Model	
Latitude	77.4126° E
Longitude	23.2599° N
Location	Bhopal (M.P.)

- Next step is to set the boundary condition and solver for the simulation, solver setting for the simulation is given in Table 5.(Ref. [3])
- The mesh generations is then imported to ANSYS FLUENT software for simulation after the experimental conditions application. The analysis and simulation of solar collect or model is performed with consideration of different temperature on both the materials and pipe designs. The analysis was performed in ANSYS workbench.

VII. RESULTS

CASE 1 Air with Porous Medium

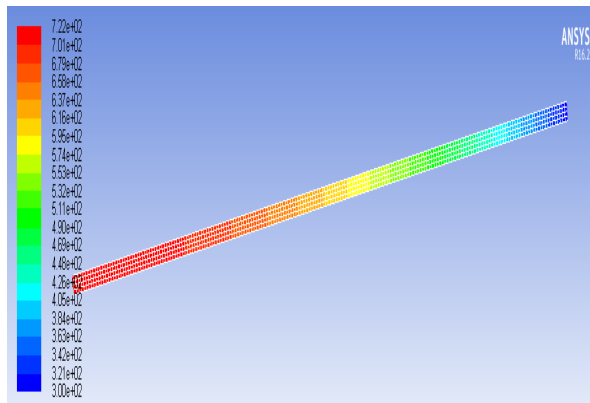

(a)

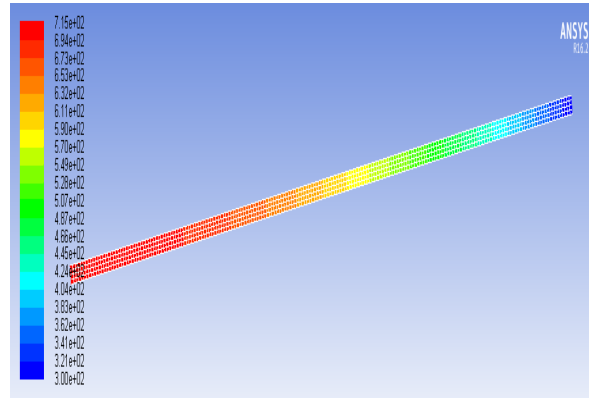

(b)

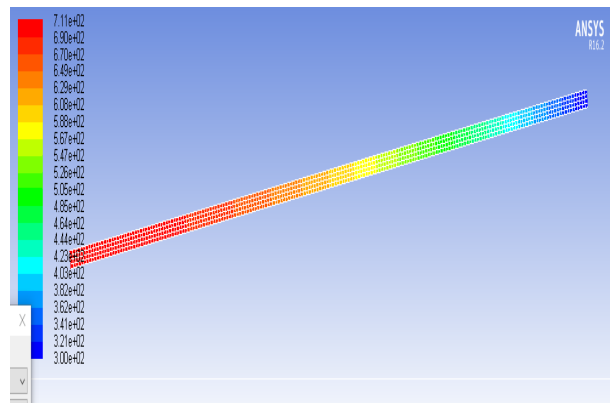

(c)

Fig. 3. Temperature at (a) 1 l/min (b) 2 l/min (c) 5 l/min.

Water with Porous Medium

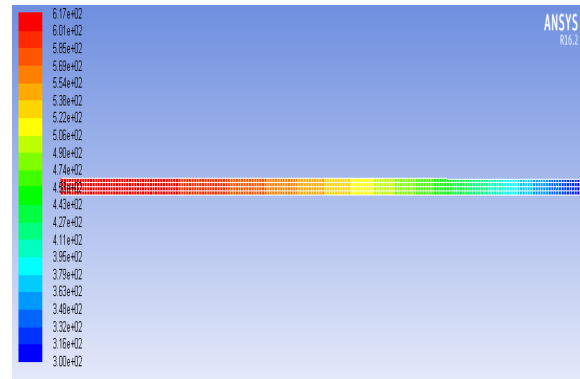

(a)

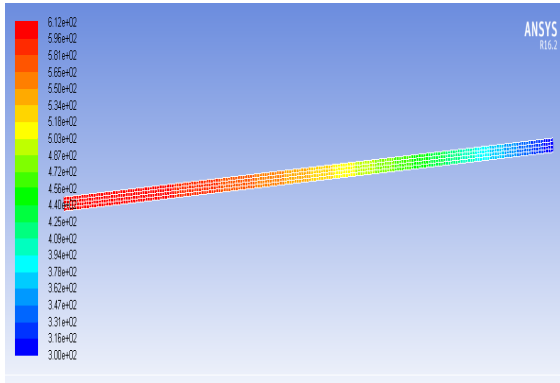

(b)

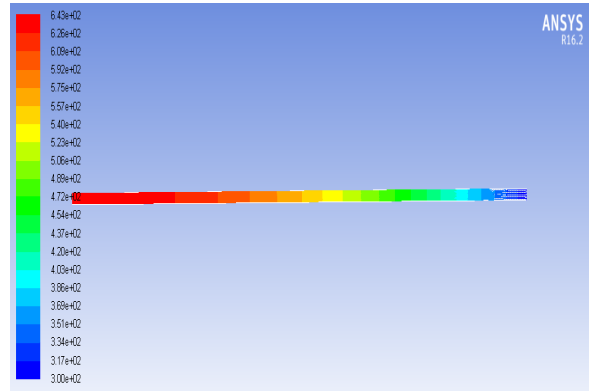

(b)

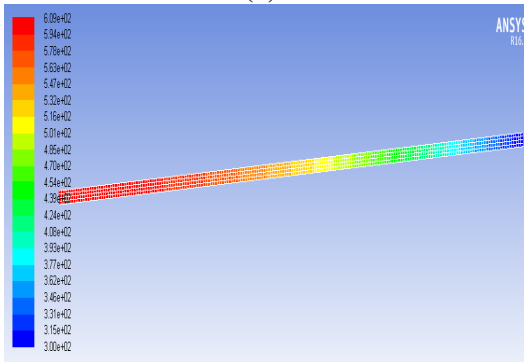

(c)

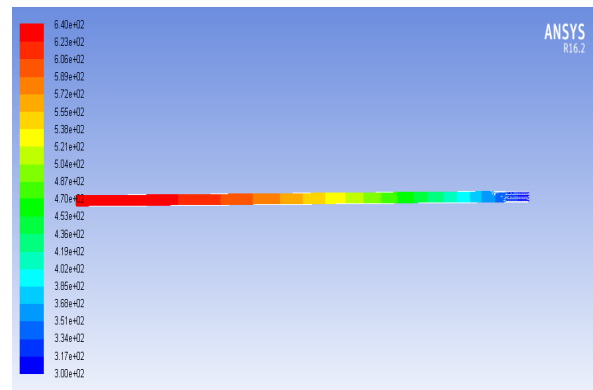

(c)

Fig : Temperature at (a) 1 l/min (b) 2 l/min (c) 5 l/min

Fig : Temperature at (a) 1 l/min (b) 2 l/min (c) 5 l/min

Nano Fluid ($Al_2O_3 \cdot H_2O$) With Porous Medium

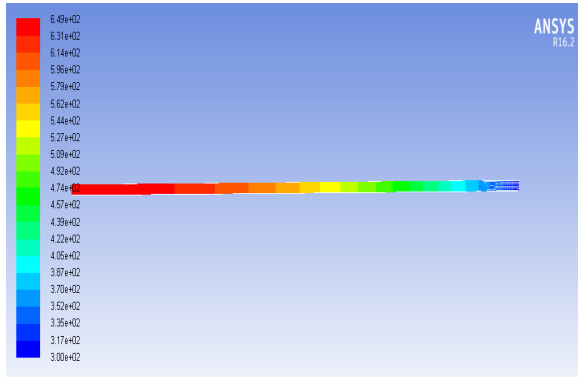

(a)

Tabular Representation Of Values Obtained As Results In Different Temperature Conditions.

Table 6: Results for Air in Porous Medium.

Mass Flow Rate	Temperature (k)	Pressure (Pa)
1 l/min	722	4.16
2 l/min	715	8.52
5 l/min	711	2.8

Table 7: Results for Water in Porous Medium.

Mass Flow Rate	Temperature (k)	Pressure (Pa)
1 l/min	617	4.06
2 l/min	612	8.32
5 l/min	609	2.8

Table 8: Results for Nano fluid (Al₂O₃. H₂O) in Porous Medium.

Mass Flow Rate	Temperature (k)	Pressure (Pa)
1 l/min	649	4.18
2 l/min	643	8.31
5 l/min	640	2.98

Temperature Variation Graphs Of Different Fluids Used (At 1 l/min)

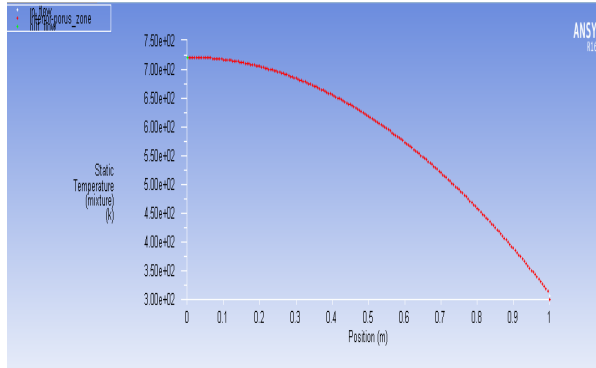

(Air)

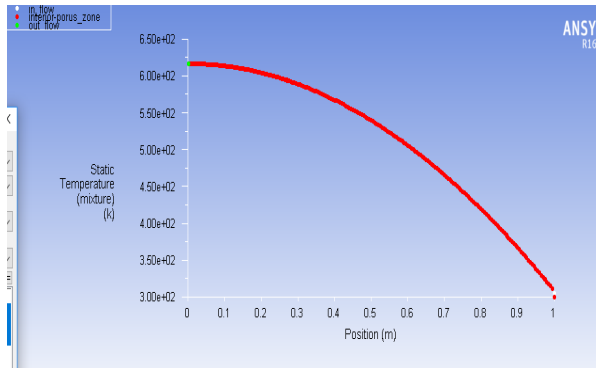

(Water)

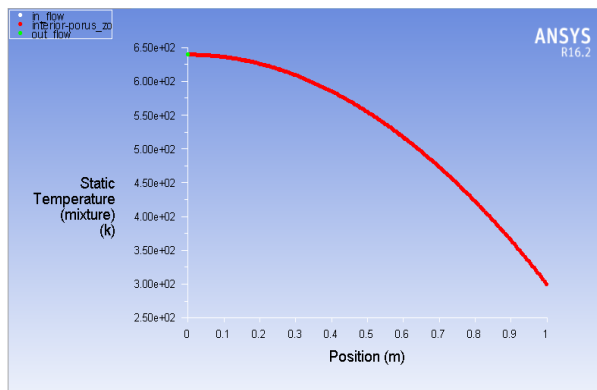

(Nano Fluid)

VIII. CONCLUSION

Based on the results mentioned in the previous chapter following conclusion can be drawn;

- The solar receiver model is simulated with porous media for three materials at three mass flow rate.
- As the mass flow rate is increased the rise in temperature starts to decrease.
- In the case of Air heat transfer rate is most as compared to water and nano fluid but the heat capacity of air is low which doesn't make it suitable for our use.
- There is around 6 percent of increase in heat transfer when water based Nano fluid is used instead of water.
- Due to use of porous medium however there is a considerable increase in pressure so as to maintain the velocity of the flowing fluid.
- As the mass flow rate increase pressure tends to increase but after a point pressure show opposite trend i.e. it decreases in all the cases.

IX. FUTURE WORK

Although the research fulfilled it's designing criteria but there is scope for some further research. Some of them are discussed below:

- In this research a CFD simulation of porous material in receiver tube of parabolic trough solar collector is done. The results of the simulation can be validated experimentally.
- Studies of different concentration of Nano fluid and their trends can be tested.
- Effect of various material as the porous medium on the thermal behavior of Parabolic trough solar collector can be tested.
- Effect of various other working fluid with porous medium can also be tested.

REFERENCES

[1]. Germilly Barreto, Paulo Canhoto, Manuel Collares-Pereira (2018). "Three-dimensional modelling and analysis of solar radiation absorption in porous volumetric receivers" *Applied Energy*, **215**: 602–614.

[2]. Alibakhsh Kasaeian, Amin Toghi Eshghi, Mohammad Sameti. (2015) "A review on the applications of nano fluids in solar energy systems" *Renewable and Sustainable Energy Reviews* **43**: 584–598.

[3]. A.Z. Hafez, A.M. Attia, H.S. Eltwab, A.O. ElKousy, A.A. Afifi, A.G. Abdelhamid, A.N. Abdelqader, S-E.K. Fateen, K.A. El-Metwally, A. Soliman, I.M. Ismail (2018). "Design analysis of solar parabolic trough thermal collectors" *Renewable and Sustainable Energy Reviews* **82**: 1215–1260.

- [4]. Ali H.A. Al-Waeli, Miqdam T. Chaichan, Hussein A. Kazem, K. Sopian (2017). "Comparative study to use nano- (Al_2O_3 , CuO, and SiC) with water to enhance photovoltaic thermal PV/T collectors" *Energy Conversion and Management* **148**: 963–973.
- [5]. Ahmed Kadhim Hussein, Dong Li, Lioua Kolsi, Sanatana Kata, Brundaban Sahoo (2017). "A Review of Nano Fluid Role to Improve the Performance of the Heat pipe Solar Collectors" *Energy Procedia* **109**: 417–424.
- [6]. Milad Tajik Jamal-Abad, Seyfollah Saedodin, Mohammad Aminy. (2017). "Experimental investigation on a solar parabolic trough collector for absorber tube filled with porous media" *Renewable Energy* **107**: 156-163.